

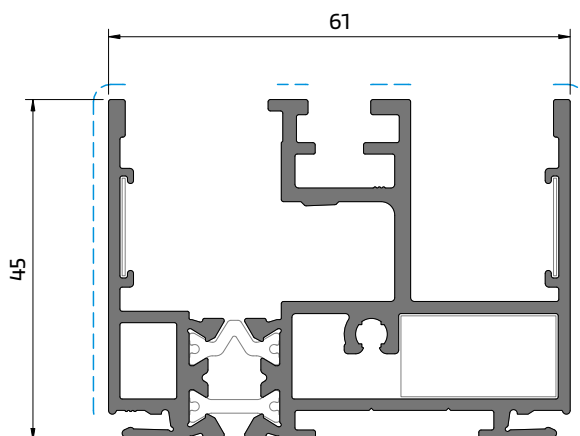

PERFIS
PROFILES
PROFILÉS



JT 05

Aro fixo PT/45º monorail
monorail PT/45º fixed frame
Cadre dormant PT/45º monorail

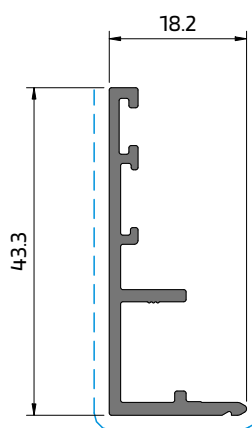

JT 80

Perfil pingadeira
Drip profile
Larmier

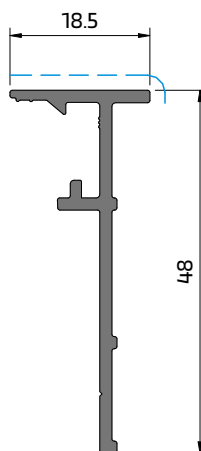

JT 57

Perfil complementar
Complementary profile
Profilé complémentaire

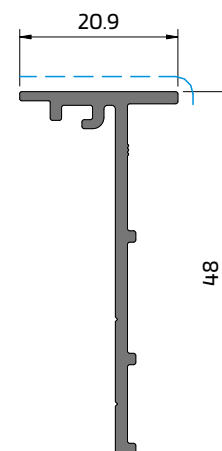

JT 58

Perfil complementar
Complementary profile
Profilé complémentaire

Para identificação dos restantes perfis e acessórios, consultar o catálogo técnico do sistema JT

For the identification of the remaining profiles and accessories, please consult the JT system technical catalogue

Pour identifier les autres profilés et accessoires, consultez le catalogue technique du système JT

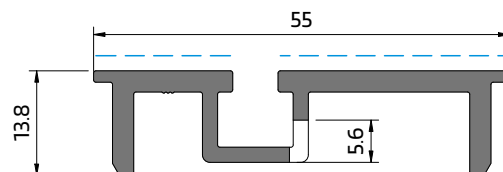
**SO 58**

Tampa baixa para caleira - Maquinado
Short drainage channel grid - Machined
Grille bas pour gouttière de vidange - Usiné

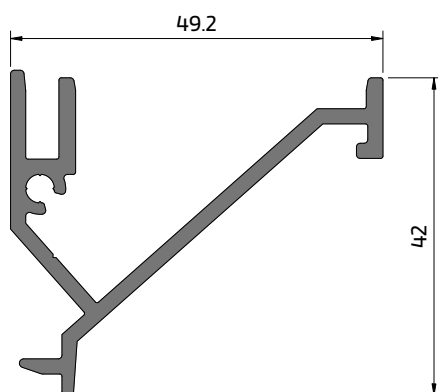
**JT 49**

Perfil fixação da tampa de caleira
(Perfil anodizado - Preto ou Natural)
Drainage channel grid profile
(Anodised profile - Black or Natural)
Profilé pour fixation de grille pour gouttière de vidange
(Profilé anodisé - Noir ou Naturel)

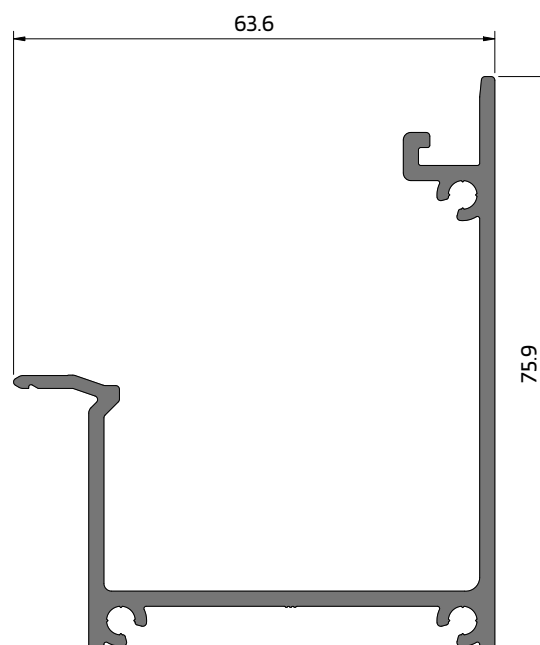
**JT 48**

Caleira
Drainage channel
Gouttière de vidange

Para identificação dos restantes perfis e acessórios, consultar o catálogo técnico do sistema JT

For the identification of the remaining profiles and accessories, please consult the JT system technical catalogue

Pour identifier les autres profilés et accessoires, consultez le catalogue technique du système JT



ACESSÓRIOS
ACCESSORIES
ACCESSOIRES

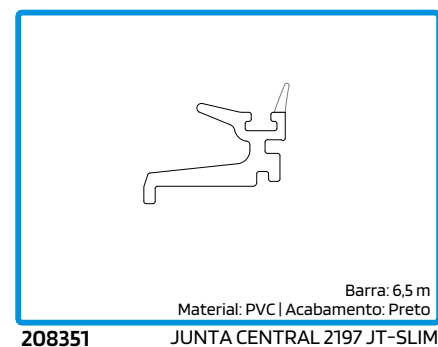
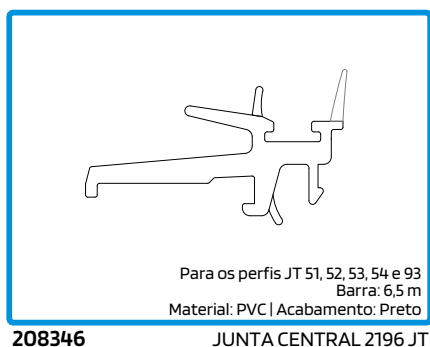
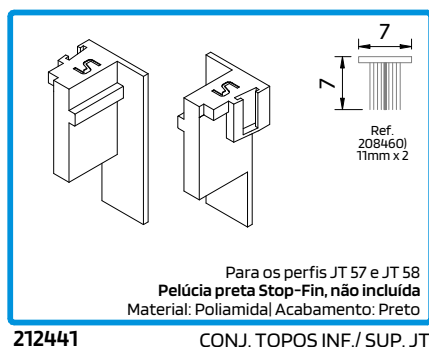
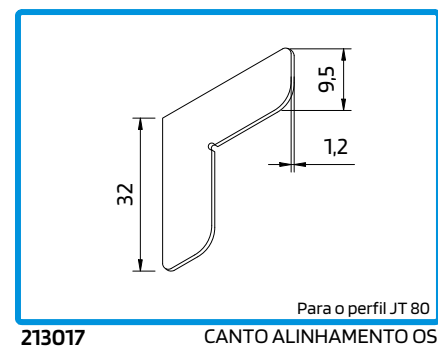
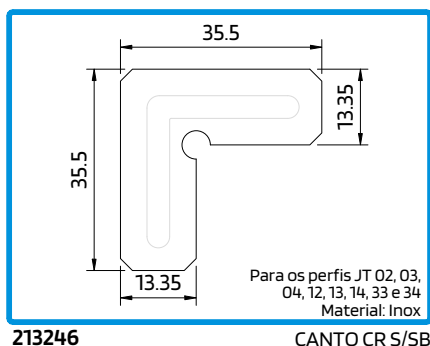
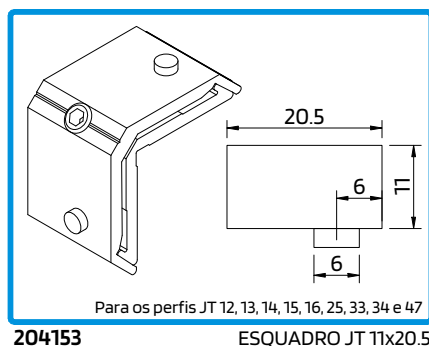
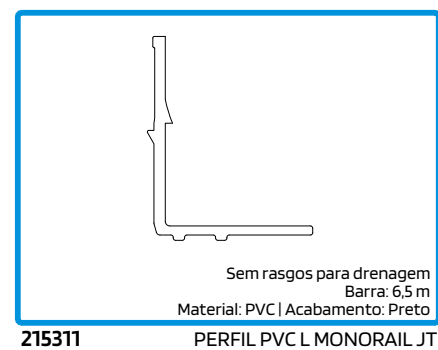
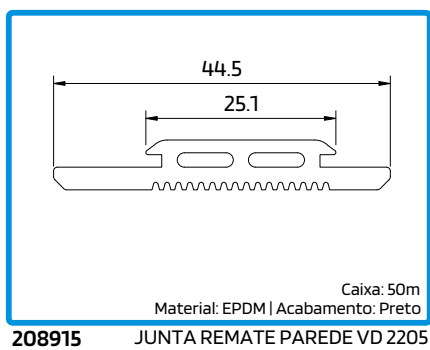
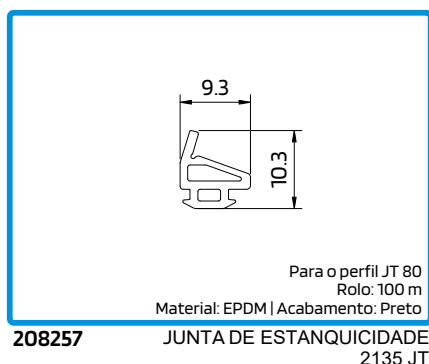
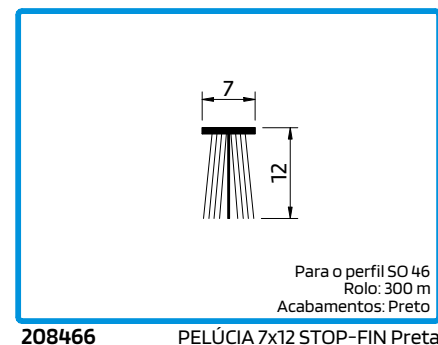
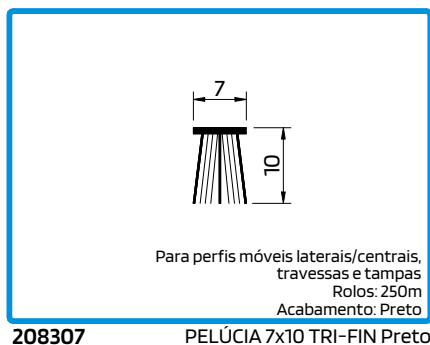
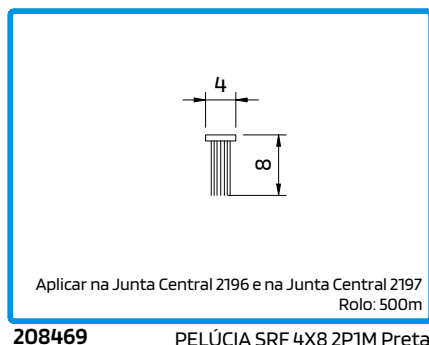



ACESSÓRIOS
ACCESSORIES
ACCESSOIRES

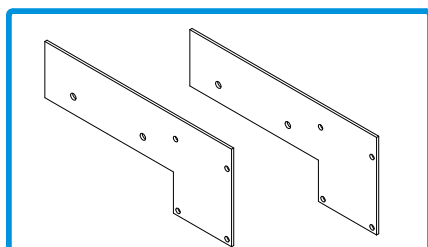

Aplicar nos perfis JT 14, JT 48 e JT 49
Material: Alumínio (2mm espessura)
Acabamentos: Bruto, Anodizados Natural e Preto

212436 CONJ. TOPOS CALEIRA/SOLEIRA JT 2-RAIL

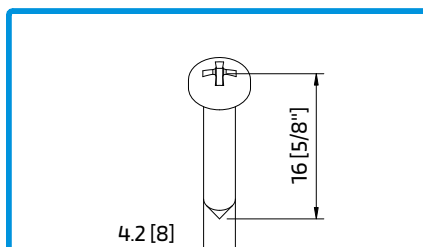

Para fixação dos Topos caleira 212436/212437/212438
Material: Inox | Acabamento: Inox

290088 PARAF. DIN981 PH 4,2x16 INOX A2

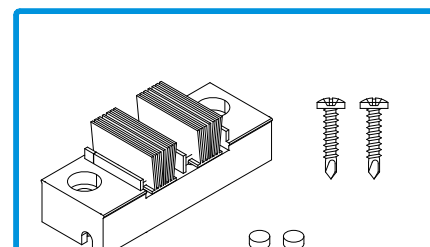

Material: EPDM | Acabamento: Preto

213303 CORTA VENTO JT FIXO

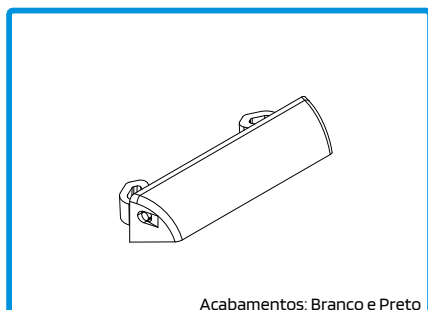

Acabamentos: Branco e Preto

210268 GOTEIRA C/ VÁLV. SVE

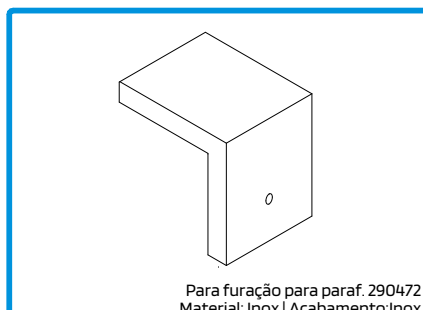

Para furação para paraf. 290472
Material: Inox | Acabamento: Inox

211209 GABARITO FURAÇÃO CALEIRA JT N°1

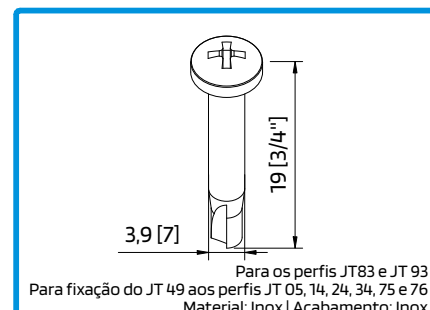

Para os perfis JT83 e JT 93
Para fixação do JT 49 aos perfis JT 05, 14, 24, 34, 75 e 76
Material: Inox | Acabamento: Inox

290472 PARAF. AT/PF CQ Ø3.9x19MM A2



Resistente a raios UV
Rolo: 2m
Material: Junta Adesiva Composta
Acabamento: Branco

299112 MEMBRANA SELAGEM 50MM (2M)



Acabamentos: Lacados

228107 LIMITADOR ABERTURA PQ SERIE CORRER

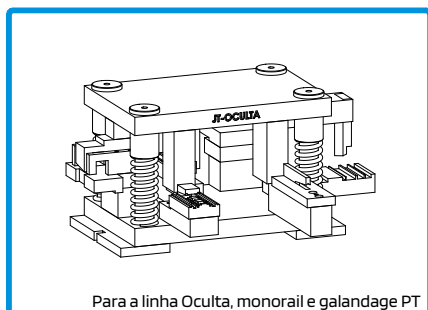

Para a linha Oculta, monorail e galandage PT

408075 CORTANTE JT-OCULTA

JANELA / PORTA DE CORRER 1 FOLHA 1-RAIL - JT-STANDARD
 1 SASH SLIDING WINDOW / DOOR 1-RAIL - JT-STANDARD
 FENÊTRE / PORTE-FENÊTRE COULISSANT 1 VANTAUX 1-RAIL - JT-STANDARD

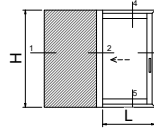

PERFIS PROFILES PROFILÉS					
CÓDIGO CODE CODE	DESIGNAÇÃO DESIGNATION NOMINATION	CORTE HORIZ. HORIZONTAL CUT COUPE HORIZ.	CORTE VERT. VERTICAL CUT COUPE VERTICALE	QUANT. QUANTITY QUANTITE	CORTE CUT COUPE
JT 05	ARO FIXO FIXED FRAME CADRE DORMANT	2L+127	H	2 + 2	
JT 51	PERFIL CENTRAL CENTRAL PROFILE PROFILÉ CENTRAL	-	H-74	1	
JT 57	PERFIL COMPLEMENTAR Complementary profile Profilé complémentaire	-	H-98	1	
JT 67	PERFIL LATERAL LATERAL PROFILE PROFILÉ LATÉRAL	-	H-74	1	
JT 63	TRAVESSA SUP/INF UP/LW TRANSOM TRAVERSE SUP/INF	L-38	-	2	
JT 80	PERFIL PINGADEIRA DRIP PROFILE LARMIER	L+79 L+40	H-4 H-3	1 2 + 1	
JT 81	PERFIL COMPLEMENTAR Complementary profile Profilé complémentaire	L+4 L+62	H-46	1 + 1	
JT 87	GUIA GUIDE GUIDE	2L-65	-	1	
208346	JUNTA CENTRAL 2196 CENTRAL JOINT JOINT CENTRALE	-	H-74 H-98	1	
215311	PERFIL PVC L JT MONORAIL L PVC PROFILE PROFILÉ PVC L	2L+94	H-34	2 + 2	
SO 46	PERFIL REMATE FINISHING PROFILE PROFILÉ DE FINITION	-	H-92	1	
SO 47	PERFIL REMATE FINISHING PROFILE PROFILÉ DE FINITION	-	H-91	1	
SO 48	PERFIL REMATE FINISHING PROFILE PROFILÉ DE FINITION	L+127	H-40	1 + 1	
SO 58	PERFIL CALEIRA DRAINAGE CHANNEL GOUTTIÈRE DE VIDANGE	CONSULTAR DEPARTAMENTO TÉCNICO CONSULT TECHNICAL DEPARTMENT CONSULTER DÉPARTEMENT TECHNIQUE			
JT 49	TAMPA DE CALEIRA GRID GRILLE POUR GOUTTIÈRE DE VIDANGE				
JT 48	PERFIL FIXAÇÃO TAMPA CHANNEL GRID FIX. PROF. PROF. FIXATION GRILLE				

(1) Peças com 400mm, aplicadas aproximadamente a cada 800mm | Pieces 400mm long, applied approximately every 800mm | Pièces de 400 mm, appliquées à environ tous les 800 mm

Corrigidas as referências dos perfis

MEDIDAS VIDROS GLAZING MEASURES DIMENSIONS DES VERRES	
Lvidro(mm) GLASS VERRE	Hvidro(mm) GLASS VERRE
L-43	H-194

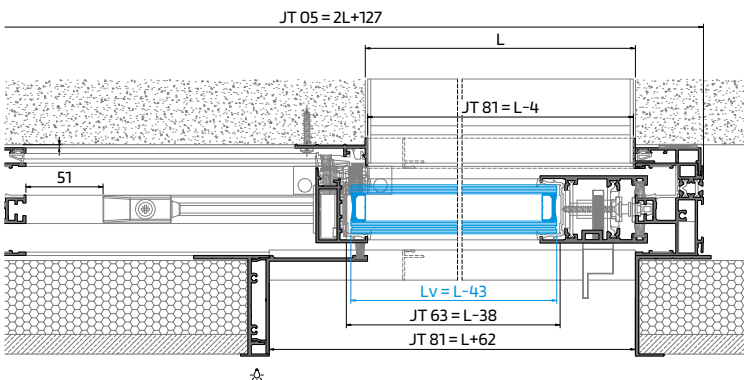
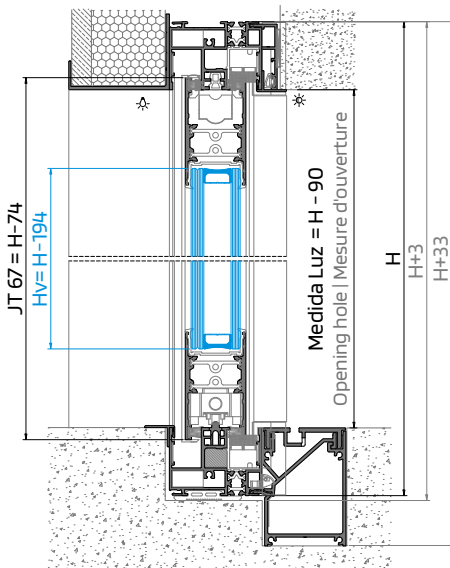

ACESSÓRIOS ACCESSORIES ACCESSOIRES			
CÓDIGO CODE CODE	DESIGNAÇÃO DESIGNATION NOMINATION		QUANT. QUANTITY QUANTITE
204153	ESQUADRO JT 1x20.5 CORNER CLEAT ÉQUERRE	JT 05	4
213246	CANTO CR 5/SB CORNER ANGLE	JT 05	8
213017	CANTO ALINHAMENTO OS ALIGNMENT CORNER ANGLE D'ALIGNEMENT	JT 80	2
205000	CARRINHO JT-SLIM ROLLER ROULETTE	JT 63	2
212422	CONJ. GUIAS SUPERIORES JT UPPER GUIDE GUIDE SUPERIEUR		*** min. 1
213303	CORTA-VENTO JT FIXO CENTRAL WATERPROOFING PILE SEAL BRASSE CENTRALE D'ETANCHÉITÉ	JT 05	2
212337	CONJ. ESTANQ. CORTA-VENTO JT CENTRAL WATERPROOFING PILE SEAL KIT KIT BRASSE CENTRALE D'ETANCHÉITÉ	JT 05	1
212199	CONJ. TOPOS LATERAL JT LATERAL END-CAPS KIT KIT D'EMBOUS LATERAUX	JT 67	1
212230	CONJ. TOPOS INTERIOR LAT. JT LATERAL INNER END-CAPS KIT KIT D'EMBOUS INTERIEUR LATÉRAUX	JT 67	1
212201	CONJ. TAMPAS TOPOS LAT. JT LATERAL END-CAP COVERS KIT KIT DE COUVERTURE POUR EMBOUTS LATÉRAUX	JT 67	1
212231	CONJ. TOPOS CENTRAIS JT CENTRAL END-CAPS KIT KIT D'EMBOUS CENTRAUX	JT 51	1
212339	CONJ. TAMPAS TOPOS CENTRAIS JT CENTRAL END-CAP COVERS KIT KIT DE COUVERTURE POUR EMBOUTS CENTRAUX	JT 51	1
212441	CONJ. TOPOS INF / SUP JT CENTRAL END-CAPS KIT KIT D'EMBOUS CENTRAUX	JT 57	1
211223	FERRAGEM MULTIPONTO CENTR. 1000 MULTIPOINT HARDWARE SERRURE MULTIPONTO		1
202491	CONTRA-FECHO ANTI-LEVANTAMENTO MULTIPONTO MULTIPOINT HARDWARE SERRURE MULTIPONTO		2
212455	CONJ. FIX. CONTRA-FECHO AL MULTIP. JT MULTIPOINT HARDWARE SERRURE MULTIPONTO		2
212487	CENTRADOR JT P/ C-FECHO AL MULTIPONTO JT CENTERING FOR STRIKING PLATE CENTRAGE JT POUR GÂCHE		3
218149	CALÇO Nº2 P/ MULTIPONTO SOS JT N2 MULTIPOINT HARDWARE SHIM CALE N2 POUR MULTIPONT		6
212161	CONJ. CENTRADOR P/ FERRAGEM JT CENTERING KIT FOR JT HARDWARE KIT CENTRAGE POUR SERRURE JT		1 **
212371	CONJ. FIXAÇÃO JT FIXING KIT KIT FIXATION	Fixação Ferragem Multiponto	6 **
200819	PUXADOR SLIM XS - ESQUERDO LEFT HANDLE POIGNÉE GAUCHE		1
228107	LIMITADOR ABERT. PQ SERIE CORRER OPENING LIMITER LIMITÉUR D'OUVERTURE		2
218147	CALÇO REFORÇO HORIZONTAL JT-SLIM HORIZONTAL REINFORCEMENT SHIM CALE DE RENFORCEMENT HORIZONTALE		2 *
210268	GOTEIRA C/ VALV. SVE OUTSIDE FLAP VALVE CLAPE A VOLET EXTÉRIEUR	(a)	
212436	CONJ. TOPOS CALEIRA/SOLEIRA JT 2-RAIL JT 2-RAIL END-CAPS KIT KIT D'EMBOUT DE GOUTTIÈRE/SEUIL 2-RAIL		1
299112	MEMBRANA SELAGEM 50MM (2M) 50MM SEALING MEMBRANE MEMBRANE D'ETANCHÉITÉ 50MM		= L JT 48
290087	PARAF. DIN7981 PH 4,8x63 INOX A2 SCREW VIS	Fixação JT 60 e JT 69	2
290091	PARAFUSO DIN7981 PH 4,8x50 A2 SCREW VIS	Fixação JT 55 e JT 69	2
290465	PARAF. DIN7991 M5x30 A2 SCREW VIS	Para Puxador Slim XS	2
290051	PARAFUSO DIN 7504P 4,2x13 A2 SCREW VIS	Para Puxador Slim XS	2

- * Usar em folhas com vidros com peso superior a 80kg
To be used in sashes which glass weight exceed 80kg | Utiliser dans des panneaux de verre d'un poids supérieur à 80 kg
- ** Consultar Mapas de Ferragens
Consult the Hardware Maps | Consulter la Carte des Ferrures
- *** De 0-1m = 1un/folha; De 1-2m = 2un/folha; De 2-3m = 3un/folha
From 0-1m = 1un/sash; From 1-2m = 2un/sash; From 2-3m = 3un/sash
De 0-1m = 1un/vantail; De 1-2m = 2un/vantail; De 2-3m = 3un/vantail
Conforme esquemas de drenagem (Capítulo VII - Maquinações)

VEDANTES SEALS JOINTS		
CÓDIGO CODE CODE	DESIGNAÇÃO DESIGNATION NOMINATION	QUANT. QUANTITY QUANTITE
208348	JUNTA TAPA CANAL 2116 JT JOINT JOINT	1L + 2H
208099	JUNTA VIDRO U 1032 CX 32MM JT GLAZING GASKET JOINT DE VITRERIE	2L + 2H
208307	PELUCIA 7x10 TRI-FIN PRETA PILE SEAL JOINT BRASSE	5L + 7H
208466	PELUCIA 7x12 STOP-FIN PRETA PILE SEAL JOINT BRASSE	1H
208915	JUNTA 2205 JOINT JOINT	L



JANELA / PORTA DE CORRER 1 FOLHA 1-RAIL - JT-STANDARD
 COM SOLUÇÃO *RENOVATIO*
 1 SASH SLIDING WINDOW / DOOR 1-RAIL - JT-STANDARD
 WITH *RENOVATIO* SOLUTION
 FENÊTRE / PORTE-FENÊTRE COULISSANT 1 VANTAUX 1-RAIL - JT-STANDARD
 AVEC SOLUTION *RENOVATIO*

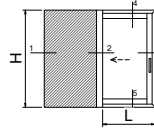

PERFIS PROFILÉS PROFILÉS					
CÓDIGO CODE CODE	DESIGNAÇÃO DESIGNATION NOMINATION	CORTE HORIZ. HORIZONTAL CUT COUPE HORIZ.	CORTE VERT. VERTICAL CUT COUPE VERTICALE	QUANT. QUANTITY QUANTITE	CORTE CUT COUPE
JT 05	ARO FIXO FIXED FRAME CADRE DORMANT	2L+127	H	2 + 2	
JT 51	PERFIL CENTRAL CENTRAL PROFILE PROFILÉ CENTRAL	-	H-74	1	
JT 57	PERFIL COMPLEMENTAR Complementary profile Profilé complémentaire	-	H-98	1	
JT 67	PERFIL LATERAL LATERAL PROFILE PROFILÉ LATÉRAL	-	H-74	1	
JT 63	TRAVESSA SUP/INF UP/LW TRANSOM TRAVERSE SUP/INF	L-38	-	2	
JT 80	PERFIL PINGADEIRA DRIP PROFILE LARMIER	L+79 L+41	H-4 H-3	2 + 1 1	
JT 81	PERFIL COMPLEMENTAR Complementary profile Profilé complémentaire	L-4	H-46	1 + 1	
JT 87	GUIA GUIDE GUIDE	2L-65	-	1	
208346	JUNTA CENTRAL 2196 CENTRAL JOINT JOINT CENTRALE	-	H-74 H-98	1 1	
215311	PERFIL PVC L JT MONORAIL L PVC PROFILE PROFILÉ PVC L	2L+94	H-34	2 + 2	
SO 46	PERFIL REMATE FINISHING PROFILE PROFILÉ DE FINITION	-	H-91	1	
SO 47	PERFIL REMATE FINISHING PROFILE PROFILÉ DE FINITION	-	H-91	1	
SO 48	PERFIL REMATE FINISHING PROFILE PROFILÉ DE FINITION	L+127	H+10		
KE 71	PERFIL REM. <i>RENOVATIO</i> FINISH. PROFILE PROFILÉ DE FINIT. <i>RENOVATIO</i>	L-8	-		

MEDIDAS VIDROS GLAZING MEASURES DIMENSIONS DES VERRES	
Lvidro(mm) GLASS WERE	Hvidro(mm) GLASS WERE
L-43	H-194

ACESSÓRIOS ACCESSORIES ACCESSOIRES			
CÓDIGO CODE CODE	DESIGNAÇÃO DESIGNATION NOMINATION		QUANT. QUANTITY QUANTITE
204153	ESQUADRO JT 1x20.5 CORNER CLEAT EQUEURRE	JT 05	4
213246	CANTO CR 5/SB CORNER ANGLE	JT 05	8
213017	CANTO ALINHAMENTO OS ALIGNMENT CORNER ANGLE D'ALIGNEMENT	JT 80	2
205000	CARRINHO JT-SLIM ROLLER ROULETTE	JT 63	2
212422	CONJ. GUIAS SUPERIORES JT UPPER GUIDE GUIDE SUPERIEUR		*** min. 1
213303	CORTA-VENTO JT FIXO CENTRAL WATERPROOFING PILE SEAL BRUSSE CENTRALE D'ETANCHÉITÉ	JT 05	2
212337	CONJ. ESTANQ. CORTA-VENTO JT CENTRAL WATERPROOFING PILE SEAL KIT KIT BRUSSE CENTRALE D'ETANCHÉITÉ	JT 05	1
212199	CONJ. TOPOS LATERAL JT LATERAL END-CAPS KIT KIT D'EMBOUTS LATÉRAUX	JT 67	1
212230	CONJ. TOPOS INTERIOR LAT. JT LATERAL INNER END-CAPS KIT KIT D'EMBOUTS INTÉRIEUR LATÉRAUX	JT 67	1
212201	CONJ. TAMPAS TOPOS LAT. JT LATERAL END-CAP COVERS KIT KIT DE COUVERTURE POUR EMBOUTS LATÉRAUX	JT 67	1
212231	CONJ. TOPOS CENTRAIS JT CENTRAL END-CAPS KIT KIT D'EMBOUTS CENTRAUX	JT 51	1
212339	CONJ. TAMPAS TOPOS CENTRAIS JT CENTRAL END-CAP COVERS KIT KIT DE COUVERTURE POUR EMBOUTS CENTRAUX	JT 51	1
212441	CONJ. TOPOS INF / SUP JT CENTRAL END-CAPS KIT KIT D'EMBOUTS CENTRAUX	JT 57	1
211223	FERRAGEM MULTIPONTO CENTR. 1000 MULTIPOINT HARDWARE SERRURE MULTIPONTO		1
202491	CONTRA-FECHO ANTI-LEVANTAMENTO MULTIPONTO MULTIPOINT HARDWARE SERRURE MULTIPONTO		2
212455	CONJ. FIX. CONTRA-FECHO AL MULTIP. JT MULTIPONTO HARDWARE STRIKING PLATE FIXING KIT KIT FIXATION GÂCHE SERRURE MULTIPONTO		2
212487	CENTRADOR JT P/ C-FECHO AL MULTIPONTO JT CENTERING FOR STRIKING PLATE CENTRAGE JT POUR GÂCHE		3
218149	CAÇO Nº2 P/ MULTIPONTO SOS JT N2 MULTIPOINT HARDWARE SHIM CALE N2 POUR MULTIPONTO		6
212161	CONJ. CENTRADOR P/ FERRAGEM JT CENTERING KIT FOR JT HARDWARE KIT CENTRAGE POUR SERRURE JT		1 **
212371	CONJ. FIXAÇÃO JT FIXING KIT KIT FIXATION	Fixação Ferragem Multiponto	6 **
200819	PUXADOR SLIM XS - ESQUERDO LEFT HANDLE POIGNEE GAUCHE		1
228107	LIMITADOR ABERT. PQ SERIE CORRER OPENING LIMITER LIMITEUR D'OUVREURE		2
218147	CALÇO REFORÇO HORIZONTAL JT-SLIM HORIZONTAL REINFORCEMENT SHIM CALE DE RENFORCEMENT HORIZONTALE		2 *
210268	GOTEIRA C/ VALV. SVE OUTSIDE FLAP VALVE CLAPE A VOLET EXTÉRIEUR		(a)
212221	CONJUNTO TAPA TOPOS KE 71 KE 71 END-CAP KIT KIT D'EMBOUT KE 71		1
212227	CONJUNTO JUNTAS ADESIVAS P/ TOPO PERFIL SOLEIRA KE 71 ADHESIVE STRIPS KIT FOR KE 71 SILL PROFILE KIT DE BANDES ADHESIVES POUR PROFILÉ DE SEUIL KE 71		1
218116	CALÇO SEPARADOR SHIM CALE		DIVERSOS DIVERSES DIVERS
290087	PARAF. DIN 991 PH 4,8x63 INOX A2 SCREW VIS	Fixação JT 60 e JT 69	2
290091	PARAFUSO DIN 991 PH 4,8x50 A2 SCREW VIS	Fixação JT 55 e JT 69	2
290465	PARAF. DIN 991 M5x30 A2 SCREW VIS	Para Puxador Slim XS	2
290051	PARAFUSO DIN 7504P 4,2x13 A2 SCREW VIS	Para Puxador Slim XS	2

- * Usar em folhas com vidros com peso superior a 80kg
To be used in sashes which glass weight exceed 80kg | Utiliser dans des panneaux de verre d'un poids supérieur à 80 kg
- ** Consultar Mapas de Ferragens
Consult the Hardware Maps | Consulter la Carte des Ferrures
- *** De 0-1m = 1un/folha; De 1-2m = 2un/folha; De 2-3m = 3un/folha
From 0-1m = 1un/sash; From 1-2m = 2un/sash; From 2-3m = 3un/sash
De 0-1m = 1un/folha; De 1-2m = 2un/folha; De 2-3m = 3un/folha

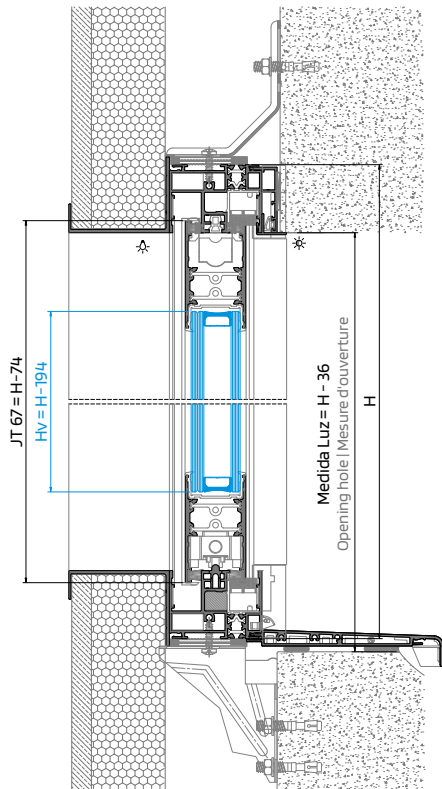

VEDANTES SEALS JOINTS		
CÓDIGO CODE CODE	DESIGNAÇÃO DESIGNATION NOMINATION	QUANT. QUANTITY QUANTITE
208348	JUNTA TAPA CANAL 2116 JT JOINT JOINT	1L + 2H
208099	JUNTA VIDRO U 1032 CX 32MM JT GLAZING GASKET JOINT DE VITRAGE	2L + 2H
208307	PELUCIA 7x10 TRI-FIN PRETA PILE SEAL JOINT BRUSSE	5L + 7H
208466	PELUCIA 7x12 STOP-FIN PRETA PILE SEAL JOINT BRUSSE	1H

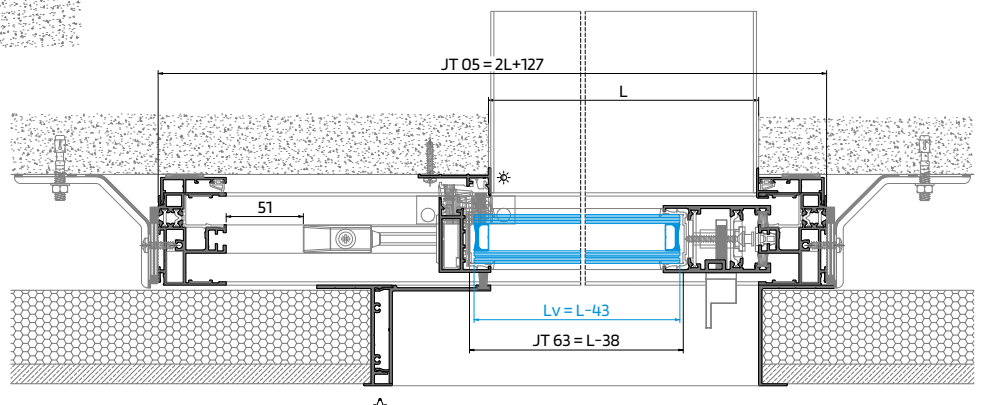

JANELA / PORTA DE CORRER 1 FOLHA 1-RAIL - LINHA JT-SLim
 1 SASH SLIDING WINDOW / DOOR 1-RAIL - JT-SLim LINE
 FENÊTRE / PORTE-FENÊTRE COULISSANT 1 VANTAUX 1-RAIL - LIGNE JT-SLim

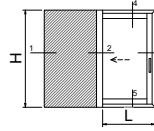

PERFIS PROFILÉS PROFILÉS					
CÓDIGO CODE CODE	DESIGNAÇÃO DESIGNATION NOMINATION	CORTE HORIZ. HORIZONTAL CUT COUPE HORIZ.	CORTE VERT. VERTICAL CUT COUPE VERTICALE	QUANT. QUANTITY QUANTITE	CORTE CUT COUPE
JT 05	ARO FIXO FIXED FRAME CADRE DORMANT	2L+67	H	2+2	
JT 55	PERFIL CENTRAL CENTRAL PROFILE PROFILÉ CENTRAL	-	H-74	1	
JT 58	PERFIL COMPLEMENTAR Complementary profile Profilé complémentaire	-	H-98	1	
JT 60	PERFIL LATERAL LATERAL PROFILE PROFILÉ LATÉRAL	-	H-74	2	
JT 69	TRAVESSA SUP/INF UP/LW TRANSOM TRAVERSE SUP/INF	L-23	-	2	
JT 80	PERFIL PINGADEIRA DRIP PROFILE L'ARMIER	L-19 L+40	H-4 H-3	1 2+1	
JT 81	PERFIL COMPLEMENTAR Complementary profile Profilé complémentaire	L-4 L+62	H-46	1+1	
JT 87	GUIA GUIDE GUIDE	2L-75	-	1	
208351	JUNTA CENTRAL 2197 CENTRAL JOINT JOINT CENTRALE	-	H-74 H-98	1 1	
215311	PERFIL PVC L JT MONORAIL L PVC PROFILE PROFILÉ PVC L	2L+34	H-34	2+2	
SO 46	PERFIL REMATE FINISHING PROFILE PROFILÉ DE FINITION	-	H-92	1	
SO 47	PERFIL REMATE FINISHING PROFILE PROFILÉ DE FINITION	-	H-91	1	
SO 48	PERFIL REMATE FINISHING PROFILE PROFILÉ DE FINITION	L+127	H-40	1+1	
SO 58	PERFIL CALEIRA DRAINAGE CHANNEL GOUTTIERE DE VIDANGE	CONSULTAR DEPARTAMENTO TÉCNICO CONSULT TECHNICAL DEPARTMENT CONSULTER DÉPARTEMENT TECHNIQUE			
JT 49	TAMPA DE CALEIRA GRID GRILLE POUR GOUTTIERE DE VIDANGE				
JT 48	PERFIL FIXAÇÃO TAMPA CHANNEL GRID FIX. PROF. PROF. FIXATION GRILLE				

(1) Peças com 400mm, aplicadas aproximadamente a cada 800mm | Pieces 400mm long, applied approximately every 800mm | Pièces de 400 mm, appliquées à environ tous les 800 mm

Corrigidas as referências dos perfis

MEDIDAS VIDROS GLAZING MEASURES DIMENSIONS DES VERRES	
Lvidro(mm) GLASS VERRE	Hvidro(mm) GLASS VERRE
L-28	H-170

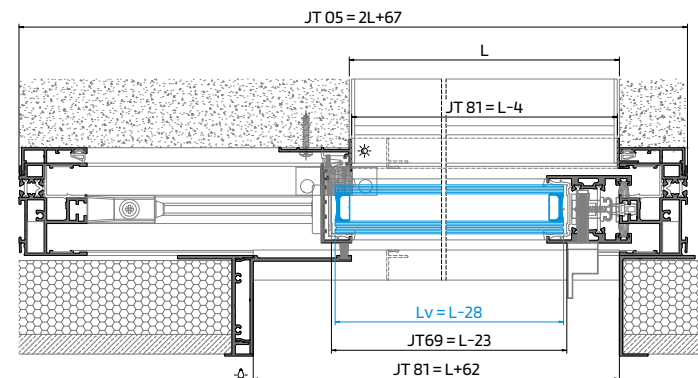
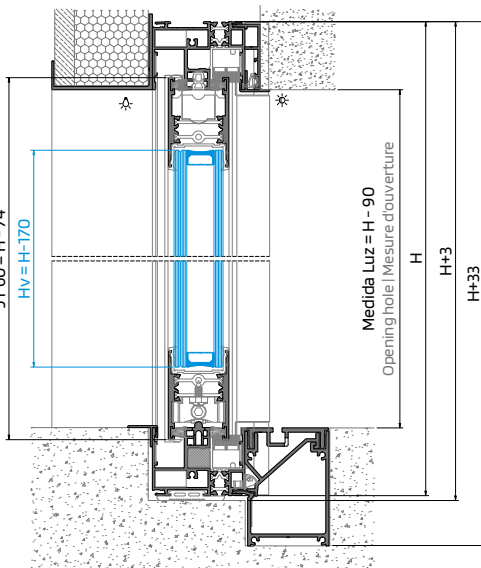

ACESSÓRIOS ACCESSORIES ACCESSOIRES			
CÓDIGO CODE CODE	DESIGNAÇÃO DESIGNATION NOMINATION	QUANT. QUANTITY QUANTITE	
204153	ESQUADRO JT Tlx20.5 CORNER CLEAT ÉQUERRE	JT 05	4
213246	CANTO CR 5/SB CORNER ANGLE	JT 05	8
213017	CANTO ALINHAMENTO OS ALIGNMENT CORNER ANGLE D'ALIGNEMENT	JT 80	2
205000	CARRINHO JT-SLIM ROLLER ROULETTE	JT 69	2
212422	CONJ. GUIAS SUPERIORES JT UPPER GUIDE GUIDE SUPERIEUR		*** min.1
213303	CORTA-VENTO JT FIXO CENTRAL WATERPROOFING PILE SEAL BRUSSE CENTRALE D'ETANCHÉITÉ	JT 05	2
212337	CONJ. ESTANQ. CORTA-VENTO JT CENTRAL WATERPROOFING PILE SEAL KIT KIT BRUSSE CENTRALE D'ETANCHÉITÉ	JT 05	1
212131	CONJ. TOPOS LATERAL JT-SLIM LATERAL END-CAPS KIT KIT D'EMBOUTS LATÉRAUX	JT 60	1
212133	CONJ. TOPOS CENTRAL JT-SLIM CENTRAL END-CAPS KIT KIT D'EMBOUTS CENTRAUX	JT 55	1
212441	CONJ. TOPOS INF / SUP JT CENTRAL END-CAPS KIT KIT D'EMBOUTS CENTRAUX	JT 58	1
212324	MULTIPONTO ALU MAC.1000 (2P) MULTIPOINT HARDWARE SERRURE MULTIPONT		1
202330	CONTRA-FECHO ALU MULTIPOINT HARDWARE SERRURE MULTIPONT		2
212455	CONJ. FIX. CONTRA-FECHO ALU MULTIP. JT STRIKING PLATE FIXING KIT KIT FIXATION GÂCHE SERRURE MULTIPONT		2
212289	CONJ. CENTRADOR P/ FERRAGEM ALU CENTERING KIT FOR ALU HARDWARE KIT CENTRAGE POUR SERRURE ALU		3
212373	CONJ. FIXAÇÃO JT-SLIM CENTRING KIT FOR ALU HARDWARE KIT CENTRAGE POUR SERRURE ALU	Fixação Ferragem Multiponto	6 **
200819	PUXADOR SLIM XS - ESQUERDO LEFT HANDLE POIGNEE GAUCHE		1
228107	LIMITADOR ABERT. PQ SERIE CORRER OPENING LIMITER LIMITEUR D'OUVRETURE		2
218147	CALÇO REFORÇO HORIZONTAL JT-SLIM HORIZONTAL REINFORCEMENT SHIM CALE DE RENFORCEMENT HORIZONTALE		2 *
210268	GOTEIRA C/ VALV. SVE OUTSIDE GLASS VALVE CLAPPE A VOLET EXTÉRIEUR		(a)
212436	CONJ. TOPOS CALEIRA/SOLEIRA JT 2-RAIL LATERAL END-CAPS KIT KIT D'EMBOUTS LATÉRAUX		1
299112	MEMBRANA SELAGEM 50MM (2M) SOMM SEALING MEMBRANE MEMBRANE D'ETANCHÉITÉ SOMM		= L JT 48
290087	PARAF. DIN7981 PH 4,8x63 INOX A2 SCREW VIS	Fixação JT 60 e JT 69	2
290091	PARAFUSO DIN7981 PH 4,8x50 A2 SCREW VIS	Fixação JT 55 e JT 69	2
290465	PARAF. DIN7991 M5x30 A2 SCREW VIS	Para Puxador SLim XS	2
290051	PARAFUSO DIN 7504P 4,2x13 A2 SCREW VIS	Para Puxador SLim XS	2
290088	PARAFUSO DIN7981 PH 4,2x16 INOX A2 SCREW VIS	Para Conj. topos caleira/soleira	12

- * Usar em folhas com vidros com peso superior a 80kg
To be used in sashes which glass weight exceed 80kg | Utiliser dans des panneaux de verre d'un poids supérieur à 80 kg
- ** Consultar Mapas de Ferragens
Consult the Hardware Maps | Consulter la Carte des Ferrures
- *** De 0-1m = 1un/folha; De 1-2m = 2un/folha; De 2-3m = 3un/folha
From 0-1m = 1un/sash; From 1-2m = 2un/sash; From 2-3m = 3un/sash
De 0-1m = 1un/vantail; De 1-2m = 2un/vantail; De 2-3m = 3un/vantail
Conforme esquemas de drenagem (Capítulo VII - Maquinações)
According to drainage schemes (Chapter VII - Machinings)

VEDANTES SEALS JOINTS		
CÓDIGO CODE CODE	DESIGNAÇÃO DESIGNATION NOMINATION	QUANT. QUANTITY QUANTITE
208348	JUNTA TAPA CANAL 2116 JT JOINT JOINT	1L + 1H
208099	JUNTA VIDRO U 1032 CX 32MM JT GLAZING GASKET JOINT DE VITRAGE	2L + 2H
208307	PELÚCIA 7x10 TRI-FIN PRETA PILE SEAL JOINT BRUSSE	5L + 4H
208469	PELÚCIA SRF 4x8 2PIM Preta PILE SEAL JOINT BRUSSE	4H
208466	PELÚCIA 7x12 STOP-FIN PRETA PILE SEAL JOINT BRUSSE	1H
208915	JUNTA 2205 JOINT JOINT	L



JANELA / PORTA DE CORRER 1 FOLHA 1-RAIL - LINHA JT-SLim
 COM SOLUÇÃO *RENOVATIO*
 1 SASH SLIDING WINDOW / DOOR 1-RAIL - JT-SLim LINE
 WITH *RENOVATIO* SOLUTION
 FENÊTRE / PORTE-FENÊTRE COULISSANT 1 VANTAUX 1-RAIL - LIGNE JT-SLim
 AVEC SOLUTION *RENOVATIO*

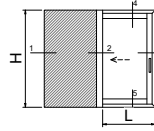

PERFIS PROFILÉS PROFILÉS					
CÓDIGO CODE CODE	DESIGNAÇÃO DESIGNATION NOMINATION	CORTE HORIZ. HORIZONTAL CUT COUPE HORIZ.	CORTE VERT. VERTICAL CUT COUPE VERTICALE	QUANT. QUANTITY QUANTITE	CORTE CUT COUPE
JT 05	ARO FIXO FIXED FRAME CADRE DORMANT	2L+67	H	2 + 2	
JT 55	PERFIL CENTRAL CENTRAL PROFILE PROFILÉ CENTRAL	-	H-74	1	
JT 58	PERFIL COMPLEMENTAR Complementary profile Profilé complémentaire	-	H-98	1	
JT 60	PERFIL LATERAL LATERAL PROFILE PROFILÉ LATÉRAL	-	H-74	2	
JT 69	TRAVESSA SUP/INF UP/LW TRANSOM TRAVERSE SUP/INF	L-23	-	2	
JT 80	PERFIL PINGADEIRA DRIP PROFILE L'ARMIER	L-19 L+40	H-4 H-3 -	2 + 1 1	
JT 81	PERFIL COMPLEMENTAR Complementary profile Profilé complémentaire	L-4	H-46	+1	
JT 87	GUIA GUIDE GUIDE	2L-75	-	1	
208351	JUNTA CENTRAL 2197 CENTRAL JOINT JOINT CENTRALE	-	H-74 H-98	1	
215311	PERFIL PVC L JT MONORAIL L PVC PROFILE PROFILÉ PVC L	2L+34	H-34	2 + 2	
SO 46	PERFIL REMATE FINISHING PROFILE PROFILÉ DE FINITION	-	H-91	1	
SO 47	PERFIL REMATE FINISHING PROFILE PROFILÉ DE FINITION	-	H-91	1	
SO 48	PERFIL REMATE FINISHING PROFILE PROFILÉ DE FINITION	L+127	H+10	2 + 1	
KE 71	PERFIL REM. <i>RENOVATIO</i> <i>RENOVATIO</i> FINISH PROFILE PROFILÉ DE FINIT. <i>RENOVATIO</i>	L-8	-	1	

MEDIDAS VIDROS GLAZING MEASURES DIMENSIONS DES VERRES	
Lvidro(mm) GLASS WIDTH	Hvidro(mm) GLASS HEIGHT
L-28	H-170

ACESSÓRIOS ACCESSORIES ACCESSOIRES			
CÓDIGO CODE CODE	DESIGNAÇÃO DESIGNATION NOMINATION	QUANT. QUANTITY QUANTITE	
204153	ESQUADRO JT 1x20.5 CORNER CLEAR EQUERRE	JT 05	4
213246	CANTO CR 5/SB CORNER ANGLE	JT 05	8
213017	CANTO ALINHAMENTO OS ALIGNMENT CORNER ANGLE D'ALIGNEMENT	JT 80	2
205000	CARRINHO JT-SLIM ROLLER ROULETTE	JT 69	2
212422	CONJ. GUIAS SUPERIORES JT UPPER GUIDE GUIDE SUPERIEUR		*** min. 1
213303	CORTA-VENTO JT FIXO CENTRAL WATERPROOFING PILE SEAL BRUSSE CENTRALE D'ETANCHÉITÉ	JT 05	2
212337	CONJ. ESTANQ. CORTA-VENTO JT CENTRAL WATERPROOFING PILE SEAL KIT KIT BRUSSE CENTRALE D'ETANCHÉITÉ	JT 05	1
212131	CONJ. TOPOS LATERAL JT-SLIM LATERAL END-CAPS KIT KIT D'EMBOÛTS LATÉRAUX	JT 60	1
212133	CONJ. TOPOS CENTRAL JT-SLIM CENTRAL END-CAPS KIT KIT D'EMBOÛTS CENTRAUX	JT 55	1
212441	CONJ. TOPOS INF / SUP JT CENTRAL END-CAPS KIT KIT D'EMBOÛTS CENTRAUX	JT 58	1
212324	MULTIPONTO ALU MAC.1000 (2P) MULTIPOINT HARDWARE SERRURE MULTIPONTO		1
202330	CONTRA-FECHO ALU MULTIPOINT HARDWARE SERRURE MULTIPONTO		2
212455	CONJ. FIX. CONTRA-FECHO ALU MULTIP. JT MULTIPONTO HARDWARE STRIKING PLATE FIXING KIT KIT FIXATION GÂCHE SERRURE MULTIPONTO		2
212289	CONJ. CENTRADOR P/ FERRAGEM ALU CENTERING KIT FOR ALU HARDWARE KIT CENTRAGE POUR SERRURE ALU		3
212373	CONJ. FIXAÇÃO JT-SLIM FIXATION KIT FOR ALU HARDWARE KIT CENTRAGE POUR SERRURE ALU	Fixação Ferragem Multiponto	6 **
200819	PUXADOR SLIM XS - ESQUERDO LEFT HANDLE POIGNÉE GAUCHE		1
228107	LIMITADOR ABERT. PQ SERIE CORRER OPENING LIMITER LIMITEUR D'OUVRETURE		2
218147	CALÇO REFORÇO HORIZONTAL JT-SLIM HORIZONTAL REINFORCEMENT SHIM CALE DE RENFORCEMENT HORIZONTALE		2 *
210268	GOTEIRA C/ VALV. SVE OUTSIDE DRAIN VALVE GLASS & VOLET EXTERIEUR		(a)
212221	CONJUNTO TAPA TOPOS KE 71 KE 71 END-CAP KIT KIT D'EMBOÛTS KE 71		1
212227	CONJUNTO JUNTAS ADESIVAS P/ TOPO PERFIL SOLEIRA KE71 ADHESIVE STRIPS KIT FOR KE71 SILL PROFILE KIT DE BANDES ADHESIVES POUR PROFILÉ DE SEUIL KE71		1
218116	CALÇO SEPARADOR SHIM CALE	DIVERSOS DIVERSES DIVERS	
290087	PARAF. DIN7981 PH 4,8x63 INOX A2 SCREW IVS	Fixação JT 60 e JT 69	2
290091	PARAFUSO DIN7981 PH 4,8x50 A2 SCREW IVS	Fixação JT 55 e JT 69	2
290465	PARAF. DIN7991 M5x30 A2 SCREW IVS	Para Puxador SLim XS	2
290051	PARAFUSO DIN 7504P 4,2x13 A2 SCREW IVS	Para Puxador SLim XS	2

- * Usar em folhas com vidros com peso superior a 80kg
To be used in sashes which glass weight exceed 80kg | Utiliser dans des panneaux de verre d'un poids supérieur à 80 kg
- ** Consultar Mapas de Ferragens
Consult the Hardware Maps | Consulter la Carte des Ferrures
- *** De 0-1m = 1un/folha; De 1-2m = 2un/folha; De 2-3m = 3un/folha
From 0-1m = 1un/sash; From 1- 2m = 2un/sash; From 2-3m = 3un/sash
De 0-1m = 1un/vantail; De 1-2m = 2un/vantail; De 2-3m = 3un/vantail
Conforme esquemas de drenagem (Capítulo VII - Maquinações)
According to drainage schemes (Chapter VII - Machinings)

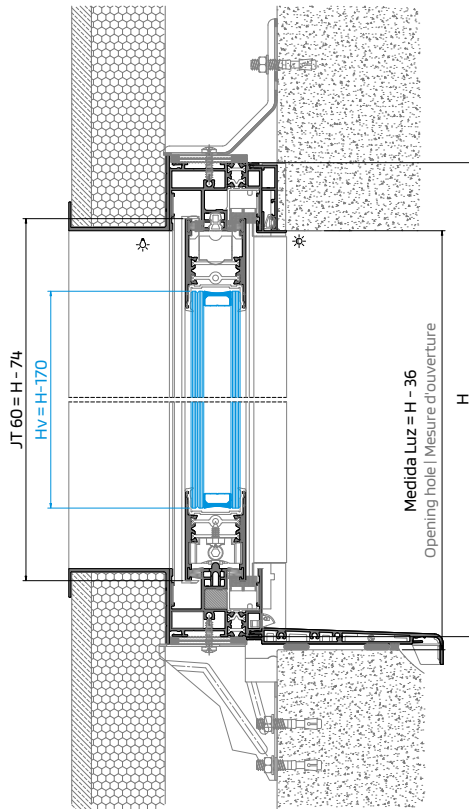

VEDANTES SEALS JOINTS			
CÓDIGO CODE CODE	DESIGNAÇÃO DESIGNATION NOMINATION	QUANT. QUANTITY QUANTITE	
208348	JUNTA TAPA CANAL 2116 JT JOINT JOINT	1L + 1H	
208099	JUNTA VIDRO U 1032 CX 32MM JT GLAZING GASKET JOINT DE VITRAGE	2L + 2H	
208307	PELÚCIA 7x10 TRI-FIN PRETA PILE SEAL JOINT BRUSSE	5L + 4H	
208469	PELÚCIA SRF 4x8 2PIM Preta PILE SEAL JOINT BRUSSE	4H	
208466	PELÚCIA 7x12 STOP-FIN PRETA PILE SEAL JOINT BRUSSE	1H	

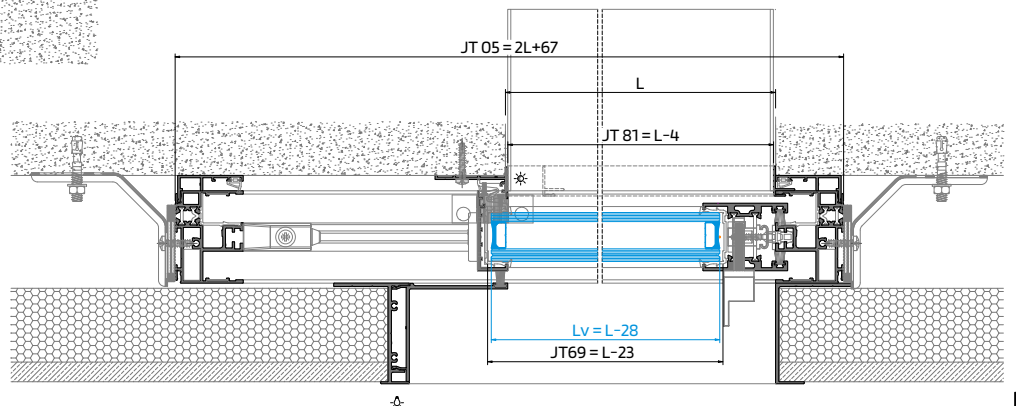



MAQUINAÇÃO DO PERFIL ARO FIXO MONORAIL (CORTE 45º)

FIXED FRAME MONORAIL PROFILE MACHINING (45° CUT)
USINAGE DU PROFIL DORMANT MONORAIL (COUPE 45°)

Maquinação de perfil aro fixo para aplicação de esquadros.
Fixed frame profile milling for corner cleat application.
Fraisage du profil dormant pour l'application de équerres.

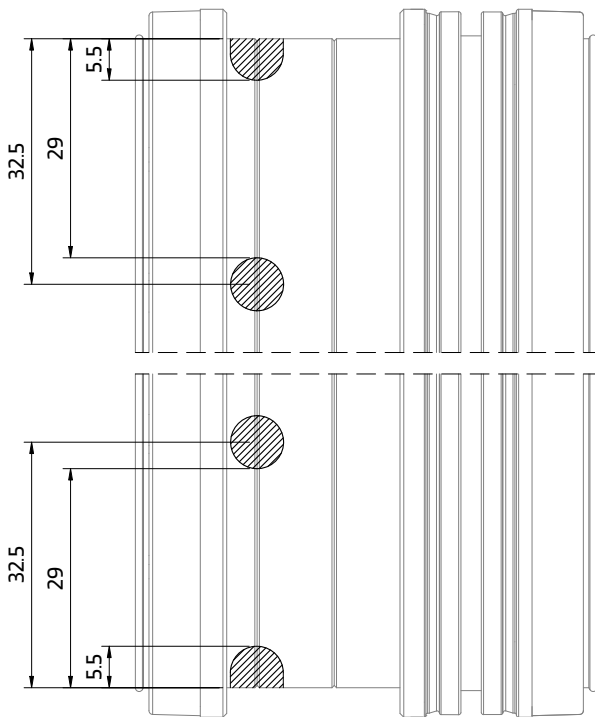
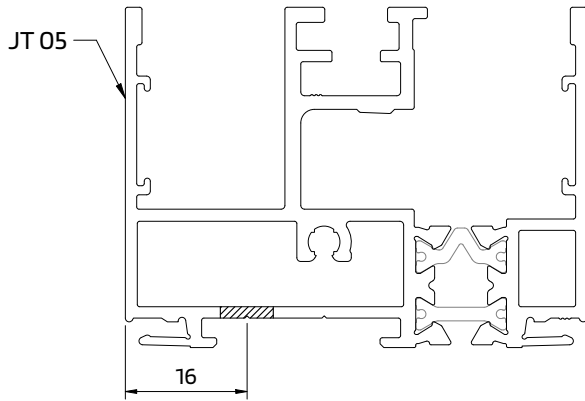

Maquinação do perfil de PVC.
PVC profile machining.
Usinage du profile en PVC.

Maquinação realizada no Cortante
Machining performed on Punching tool
Usinage réalisé dans l'Outil

Rasgo | Hole | Rainure R2: 5x30mm

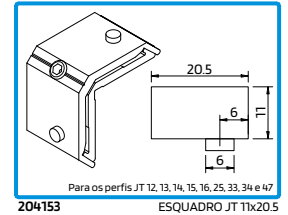
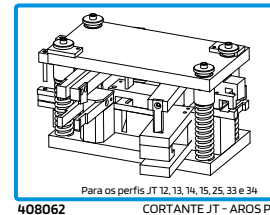
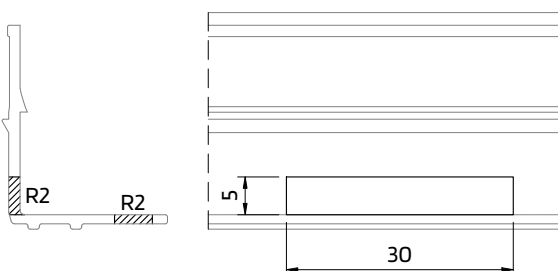

Maquinação realizada no Cortante
Machining performed on Punching tool
Usinage réalisée dans l'Outil

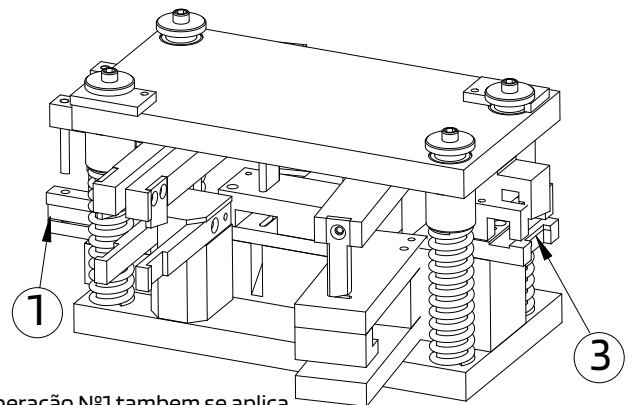

Esta operação Nº1 também se aplica aos perfis JT 14, JT 24 e JT 34

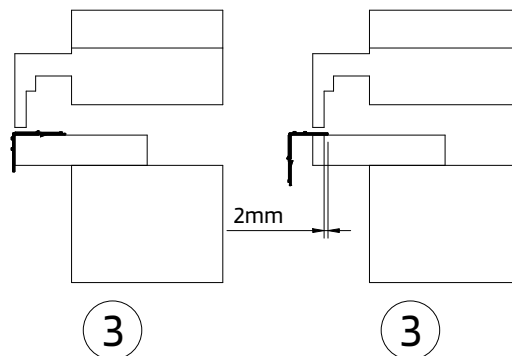
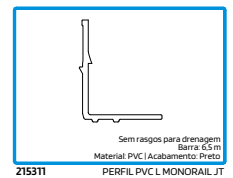
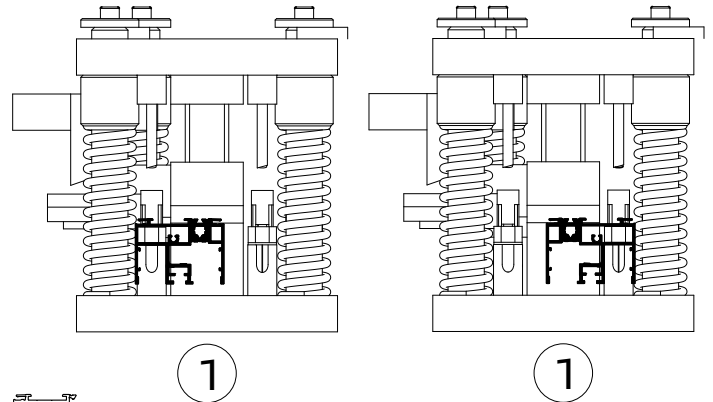



MAQUINAÇÃO DOS PERFIS ARO FIXO (CORTE 45° E 90°)

FIXED FRAME PROFILE MACHINING (45° AND 90° CUT)

USINAGE DU PROFIL DORMANT (COUPE 45° ET 90°)

Maquinações para drenagens

Water drainage machinings

Usinages pour drainages

Maquinações realizadas no Cortante

Machinings performed on Punching tool

Usinages réalisées dans l'Outil

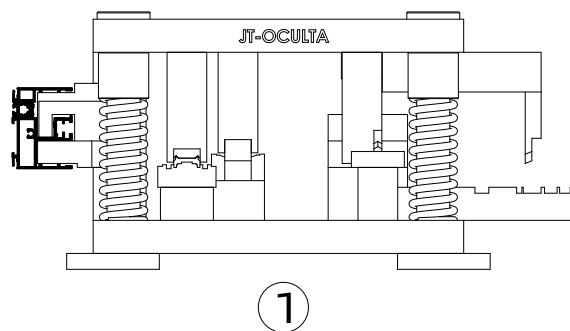
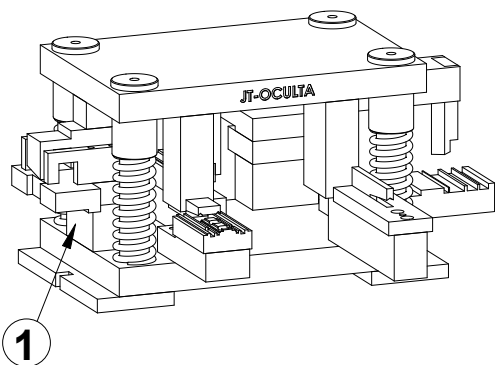
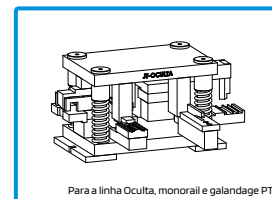

Rasgo | Hole | Rainure R3: 5x30mm

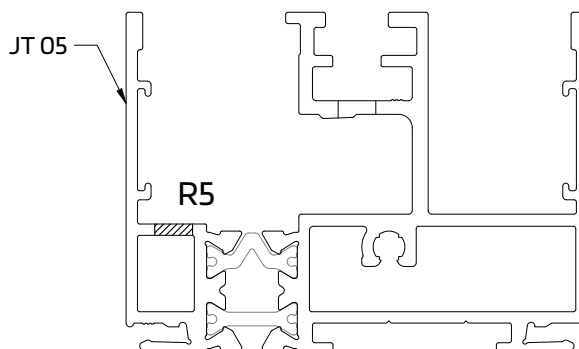
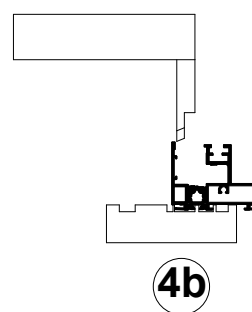
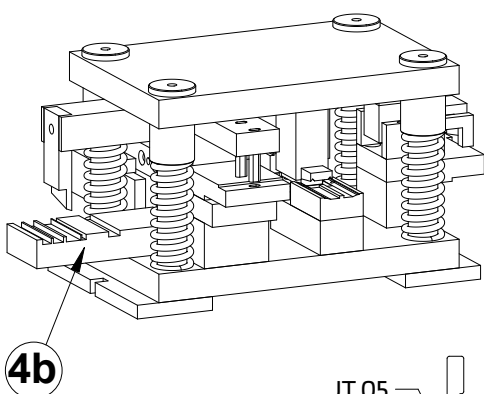
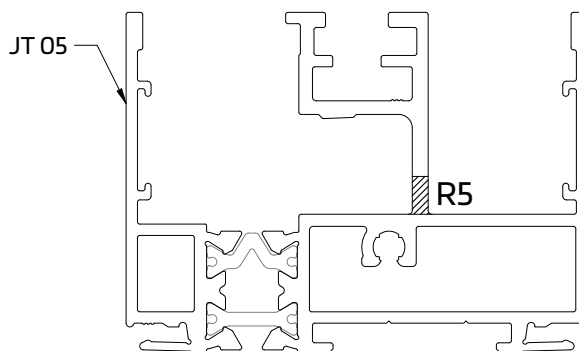



MAQUINAÇÃO DOS PERFIS ARO FIXO (CORTE 45° E 90°)

FIXED FRAME PROFILE MACHINING (45° AND 90° CUT)

USINAGE DU PROFIL DORMANT (COUPE 45° ET 90°)

Maquinações para drenagens

Water drainage machinings

Usinages pour drainages

Maquinação realizada manualmente

Manual Machining

Usinage manuel

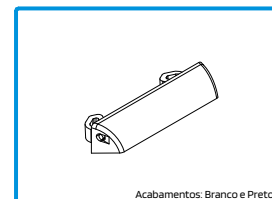

210268

Acabamentos: Branco e Preto
GOTEIRA C/ VÁLV. SVE

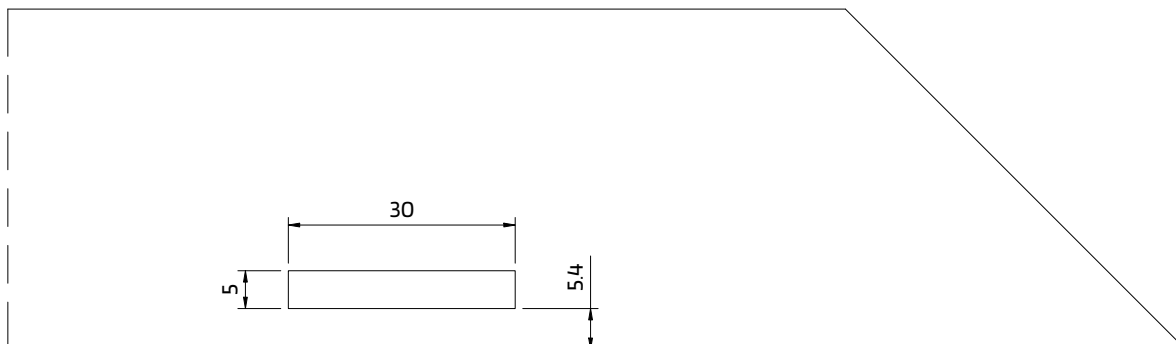
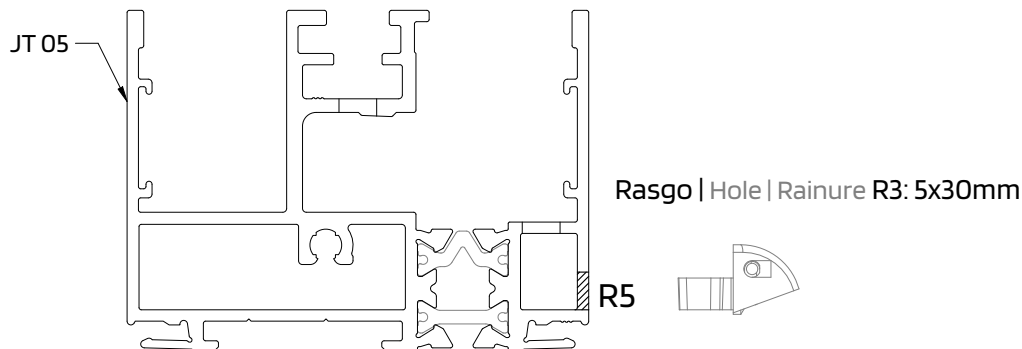

Rasgo | Hole | Rainure R3: 5x20mm

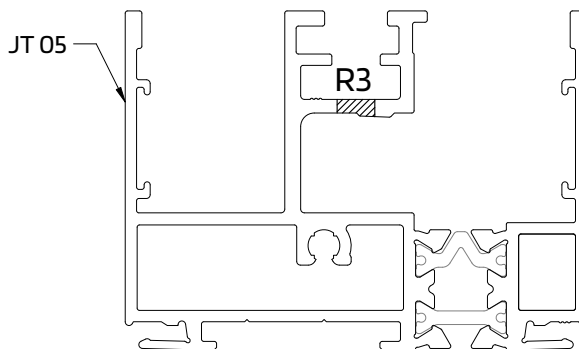



MAQUINAÇÕES NOS CORTANTES
 PUNCHING TOOLS MACHININGS
 OPÉRATIONS D'USINAGE POUR OUTILS

Janela de correr 1 e 2 folhas de embutir - Linha JT Standard
 1 and 2 sashes pocket sliding window - JT Standard Line
 Fenêtre coulissant 1 et 2 vantaux à galandage - Ligne JT Standard

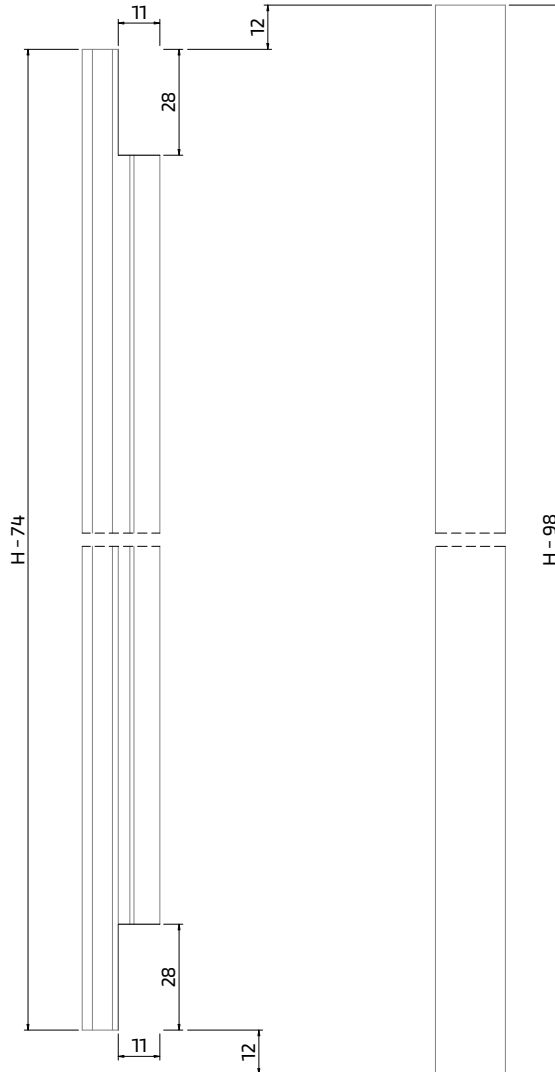
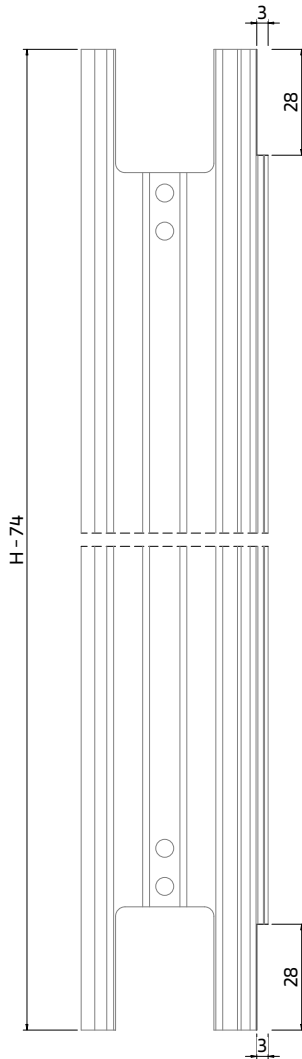
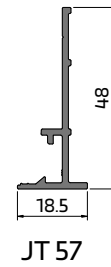
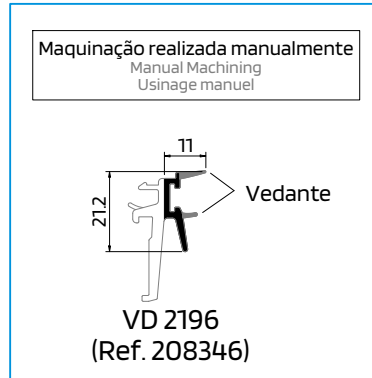
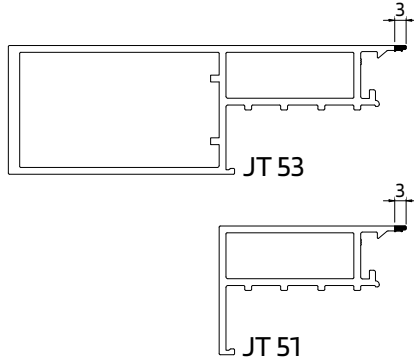



MAQUINAÇÕES NOS CORTANTES
 PUNCHING TOOLS MACHININGS
 OPÉRATIONS D'USINAGE POUR OUTILS

Janela de correr 1 e 2 folhas de embutir - Linha JT-SLim
 1 and 2 sashes pocket sliding window - JT-SLim Line
 Fenêtre coulissant 1 et 2 vantaux à galandage - Ligne JT-SLim

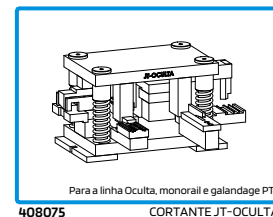
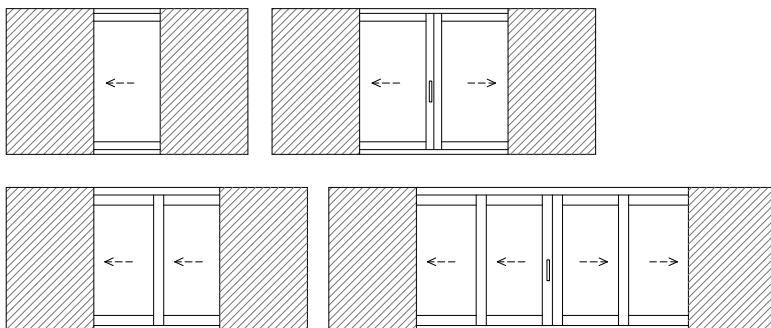

Maquinações realizadas no Cortante
 Machinings performed on Punching tool
 Usinages réalisés dans l'Outil

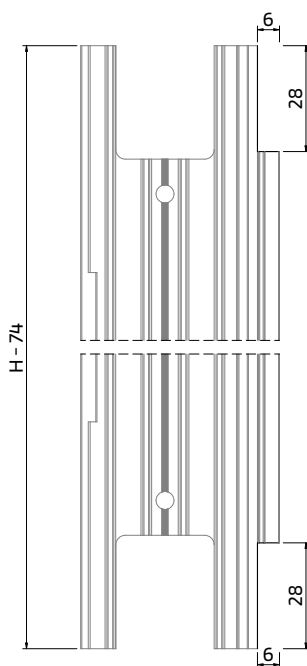
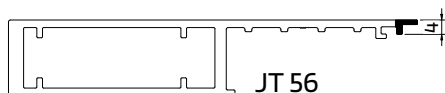
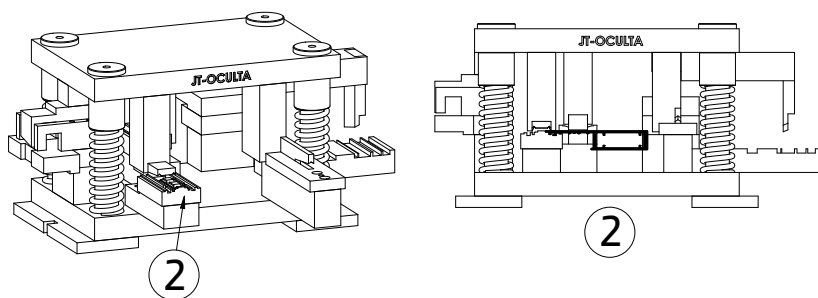

Maquinação realizada manualmente
 Manual Machining
 Usinage manuel

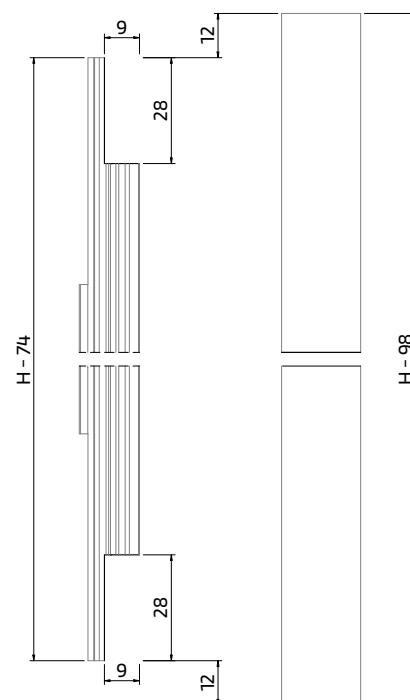
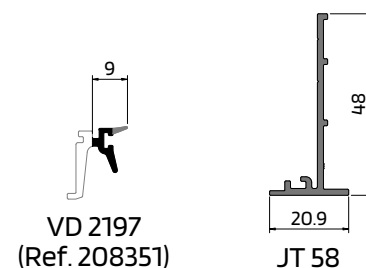



Maquinações do perfil JT 81
JT 81 profile machining
Usinage de profilé JT 81

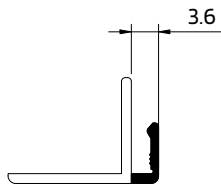

Maquinação realizada manualmente
Manual Machining
Usinage manuel

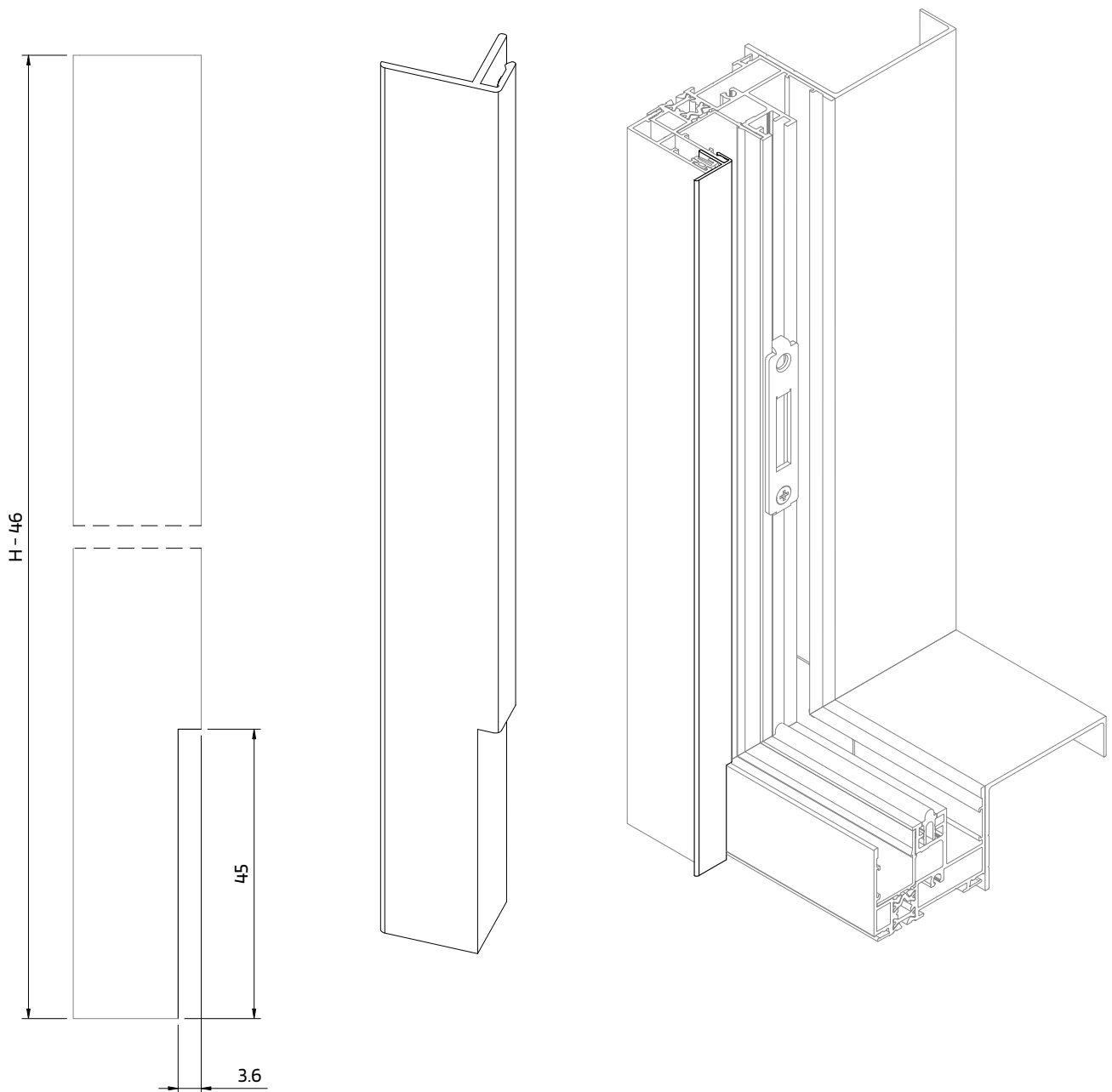



Maquinações do perfil JT 49

JT 49 profile machining

Usinage de profilé JT 49

Peças com 400mm, aplicadas aproximadamente a cada 800mm

Pieces 400mm long, applied approximately every 800mm

Pièces de 400 mm, appliquées à environ tous les 800 mm

Maquinações realizadas no Cortante

Machinings performed on Punching tool

Usinages réalisées dans l'Outil

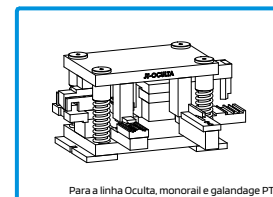

408075

CORTANTE JT-OCULTA

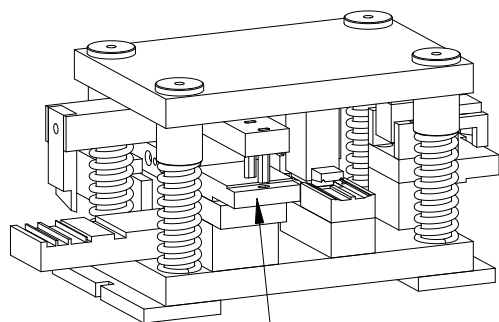

5c

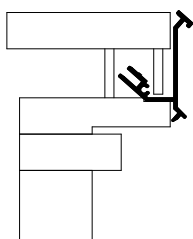

5c

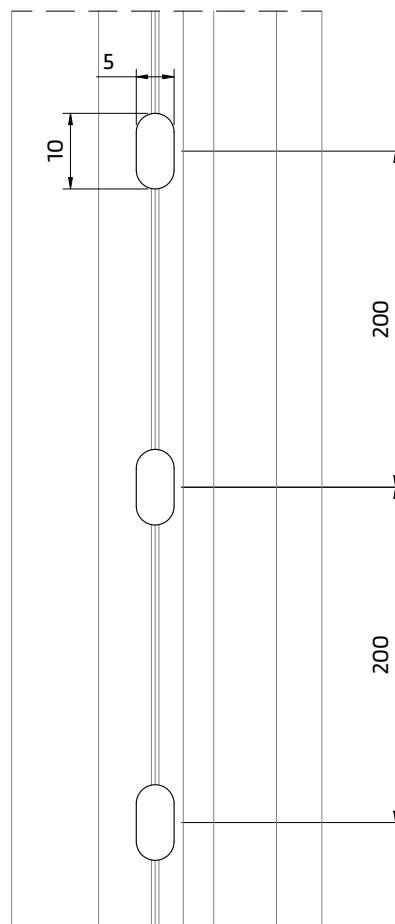
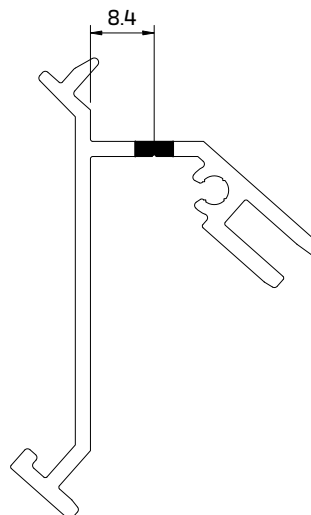



DRENAGENS POR TIPOLOGIA
DRAINAGE BY FRAME TYPOLOGY
DRAINAGE PAR TIPOLOGIE

Pormenores de drenagem para o perfil de aro fixo **PT** monorail e perfil de PVC, para tipologia de 1 folha.
 Drainage detail of fixed monorail **PT** frame profil and PVC profil, for 1 sash typologie.
 Détails de drainage pour profil dormant **PT** monorail et profil PVC, pour le typologie à 1 vantail.

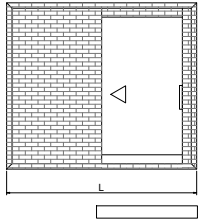

Corte | Cut | Coupe A-A

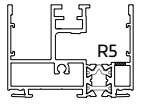

Corte | Cut | Coupe C-C

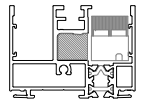

Corte | Cut | Coupe A-A

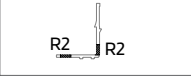

- R2: Rasgo | Hole | Rainure 5x30mm
- R3: Rasgo | Hole | Rainure 5x20mm
- R5: Rasgo | Hole | Rainure 5x30mm

Corte | Cut | Coupe B-B

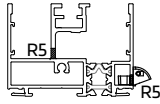

Corte | Cut | Coupe D-D

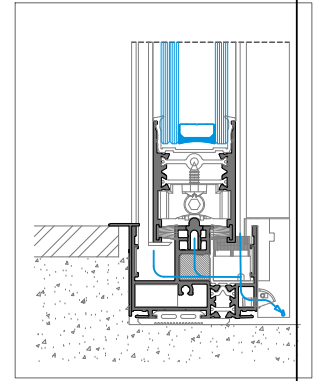
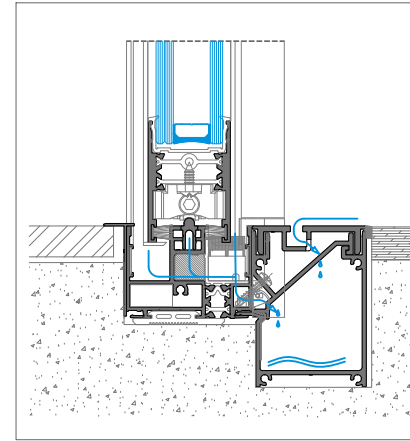
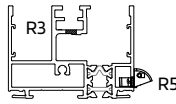

JT 05

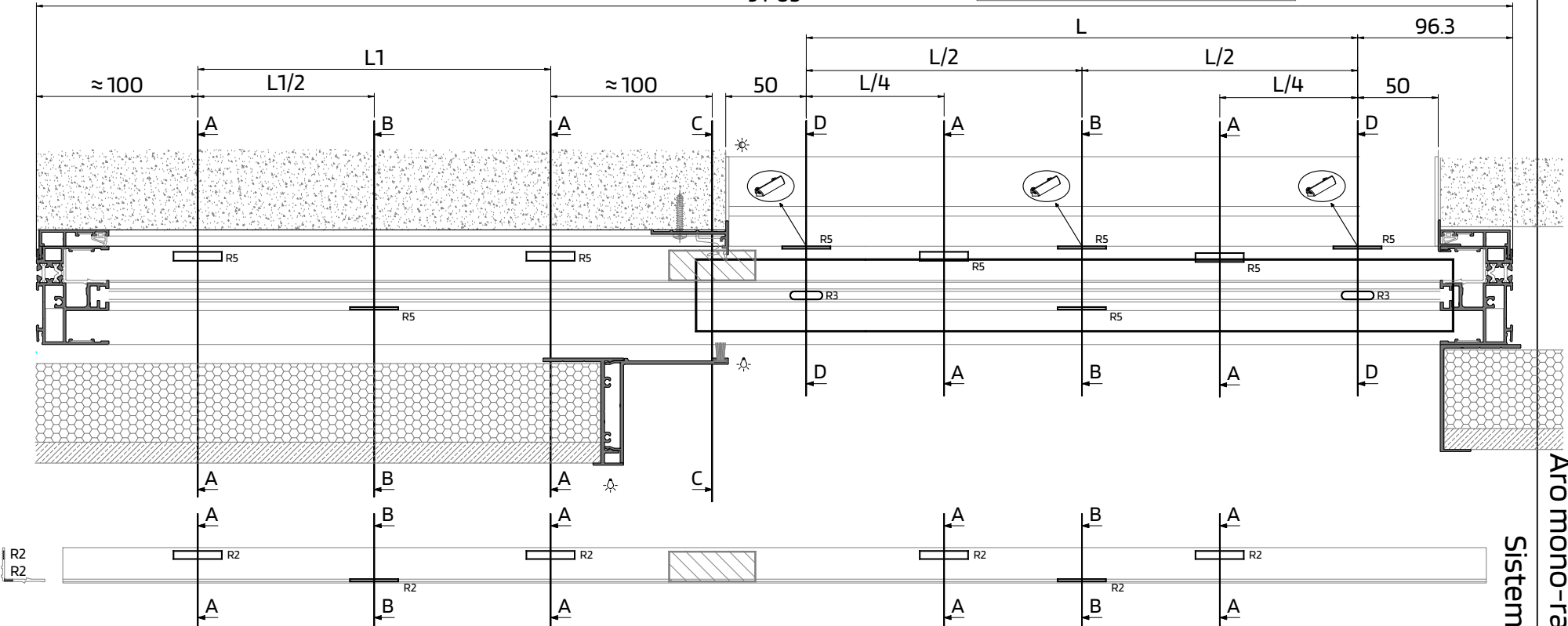

Sistema JT
Aro mono-rail JT



MAQUINAÇÕES PARA FERRAGEM MULTIPONTO ALU MAC
 ALU MAC MULTIPOINT HARDWARE MACHINING
 USINAGE POUR FERRURE MULTIPONTO ALU MAC

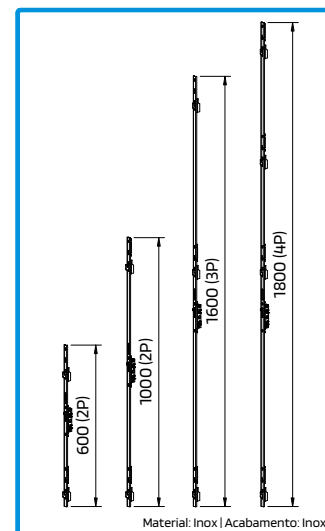
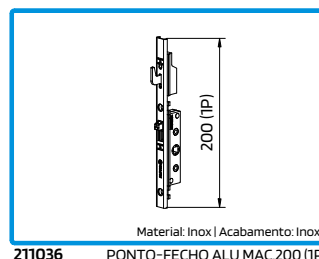

211233 MULTIPONTO ALU MAC.600 (2P)
 211234 MULTIPONTO ALU MAC.1000 (2P)
 211235 MULTIPONTO ALU MAC.1600 (3P)
 211236 MULTIPONTO ALU MAC.1800 (4P)

IMPORTANTE:

IMPORTANT | IMPORTANTE

1. A maquinação para aplicação dos contra-fechos e multipontos terão de ser feitos a partir da parte inferior do aro fixo e da folha móvel
 The machining for the application of the counter-locks and multipoints must be done from the bottom of the fixed frame and the mobile sash
 L'usinage pour l'application des contre-fermetures et des multipoints doit être effectué à partir du bas du dormant et de l'ouvrant
2. Com multiponto de **Xmm**, as medidas estão calculadas para aplicação do cremone a **Ymm** de altura e para um mínimo de altura de vão **Hmm**, com o aro JT 05
 With **Ymm** multipoint, the measurements are calculated for the handle application at a height of **Ymm** and for a minimum span height of **Hmm**, with the JT 05 frame
 Avec un multipoint de **Xmm**, les mesures sont calculées pour une application de la crémonne à une hauteur de **Ymm** et pour une hauteur de portée minimale de **Hmm**, avec le cadre JT 05
3. A medida máxima de aro fixo é de 3074mm
 The maximum measure of fixed frame is 3074mm | La mesure maximale du dormant est de 3074 mm
4. A medida máxima de aro móvel é de 3000mm
 The maximum mobile frame size is 3000 mm | La mesure maximale de l'ouvrant est de 3000 mm
5. Para medidas superiores consultar departamento técnico
 For higher measurements, consult the technical department | Pour des mesures supérieures, consulter le département technique

JT 05

CÓDIGO CODE CODE	DESIGNAÇÃO DESIGNATION NOMINATION	Medida mínima aro fixo Minimum fixed frame dimension Mesure minimale du dormant	Medida mínima aro móvel Minimum mobile frame dimension Mesure minimale de l'ouvrant	Medida mínima ao centro da quadra Minimum measurement at the centre of the square Mesure minimale au centre du carré
211036	PONTO-FECHO ALU MAC. (1P)	410mm	336mm	158mm
211233	MULTIPONTO ALU MAC. 600 (2P)	810mm	736mm	474mm
211234	MULTIPONTO ALU MAC. 1000 (2P)	1210mm	1136mm	598mm
211235	MULTIPONTO ALU MAC. 1600 (3P)	1810mm	1736mm	800mm
211236	MULTIPONTO ALU MAC. 1800 (4P)	2010mm	1936mm	800mm



MAQUINAÇÕES PARA FERRAGEM MULTIPONTO ALU MAC
ALU MAC MULTIPOINT HARDWARE MACHINING
USINAGE POUR FERRURE MULTIPOINT ALU MAC

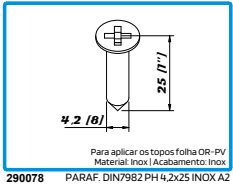
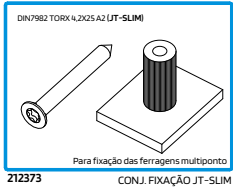
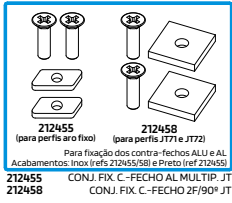
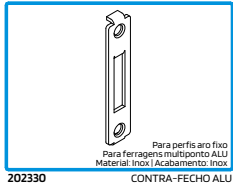
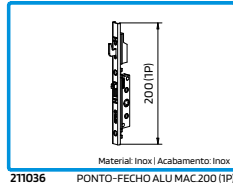
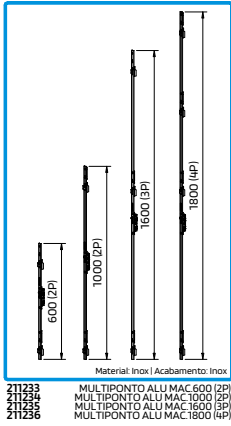
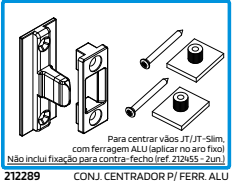

	EXPOSIÇÃO 1 EXPOSURE 1 EXPOSITION 1		EXPOSIÇÃO 2 EXPOSURE 2 EXPOSITION 2	
	CLARO BRIGHT CLAIRE	ESCURO DARK FONCÉE	CLARO BRIGHT CLAIRE	ESCURO DARK FONCÉE
ALTURA HAUTEUR H ≤ 1500	1	1	1	1
1500 < H ≤ 2000	3	3	3	3
H > 2000	4	4	4	4

Exposição 1 = Norte, Noroeste, Nordeste
 Exposure 1 = North, North-West, North-East
 Exposition 1 = Nord, Nord-Ouest, Nord-Est
 Exposição 2 = Sul, Sudeste, Sudoeste
 Exposure 2 = South, South-East, South-West
 Exposition 2 = Sud, Sud-Est, Sud-Ouest

- Ref. A: 202330
- Ref. B: 212455
- Ref. C: 212289
- Ref. D: 212373
- Ref. E: 290078

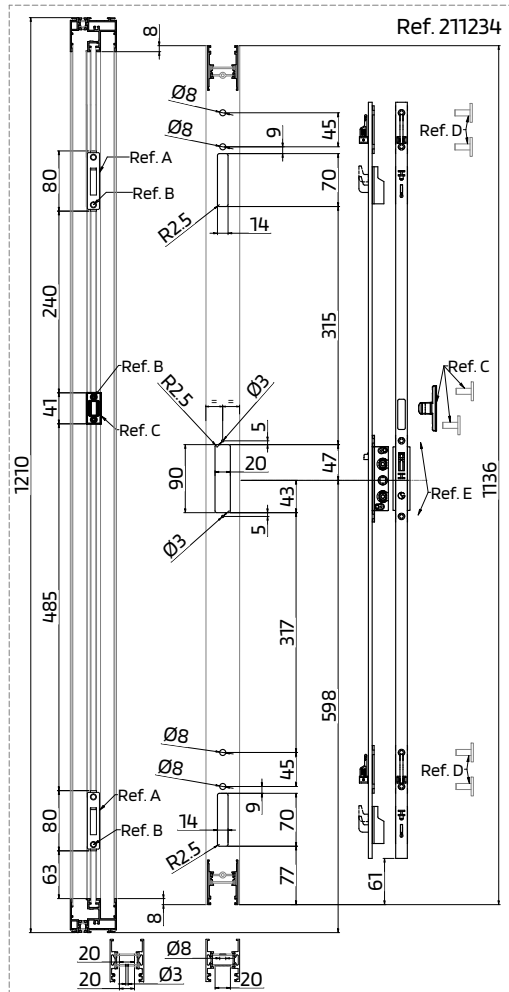
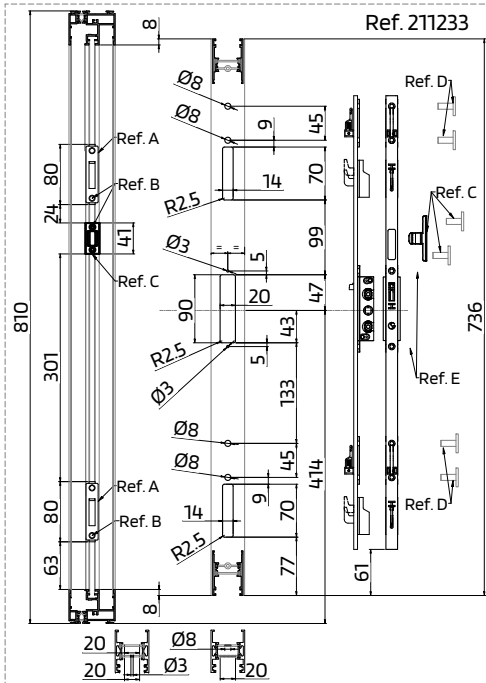
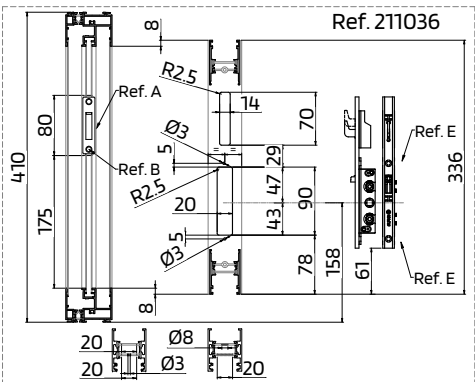



MAQUINAÇÕES PARA FERRAGEM MULTIPONTO ALU MAC
 ALU MAC MULTIPOINT HARDWARE MACHINING
 USINAGE POUR FERRURE MULTIPOINT ALU MAC

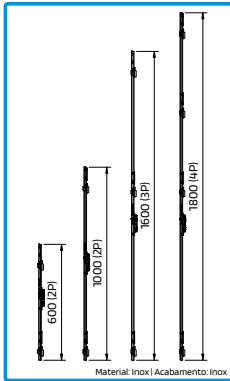

Material: Inox | Acabamento: Inox
 211233 MULTIPONTO ALU MAC 600 (2PI)
 211234 MULTIPONTO ALU MAC 1000 (2PI)
 211235 MULTIPONTO ALU MAC 1600 (3PI)
 211236 MULTIPONTO ALU MAC 1800 (4PI)

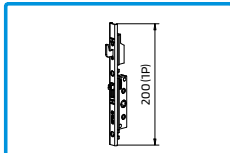

Material: Inox | Acabamento: Inox
 211036 PONTO-FECHO ALU MAC 200 (1PI)

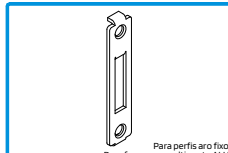

Para perfis aro fixo
 Para ferragens multiponto ALU
 Material: Inox | Acabamento: Inox
 202330 CONTRA-FECHO ALU

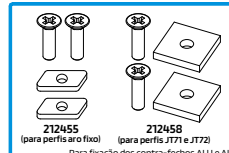

Para perfis aro fixo (para perfis JT71 e JT72)
 Para fixação dos contra-fechos ALU e AL
 Acabamentos: Inox (refs 212455/58) e Preto (ref 212455)
 212455 CONJ. FIX. C-FECHO AL MULTIP. JT
 212458 CONJ. FIX. C-FECHO 2F/90° JT

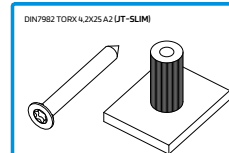

Para fixação das ferragens multiponto
 212373 CONJ. FIXAÇÃO JT-SLIM

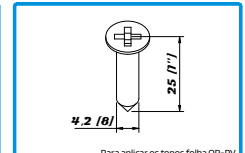

Para aplicar os topos folha GR-PV
 Material: Inox | Acabamento: Inox
 290078 PARAF. DIN7982 PH 4.2x25 INOX A2

- Ref. A: 202330
- Ref. B: 212455
- Ref. C: 212289
- Ref. D: 212373
- Ref. E: 290078

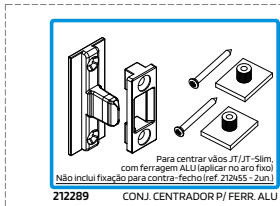

Para centrar vãos JT/JT-Slim,
 com ferragem ALU laponar no aro fixo!
 Não inclui fixação para contra-fecho (ref. 202330 - 240)
 212289 CONJ. CENTRADOR P/ FERR. ALU

	EXPOSIÇÃO 1		EXPOSIÇÃO 2		496
	EXPOSITION 1	EXPOSITION 2	EXPOSITION 1	EXPOSITION 2	
	COR		COR		
	COLOR		COLOR		
	COULEUR		COULEUR		
ALTURA HIGH HAUTEUR	CLARO BRIGHT CLAIRE	ESCURO DARK FONCÉE	CLARO BRIGHT CLAIRE	ESCURO DARK FONCÉE	
H ≤ 1500	1	1	1	1	
1500 < H ≤ 2000	3	3	3	3	
H > 2000	4	4	4	4	

Exposição 1 = Norte, Noroeste, Nordeste
 Exposure 1 = North, North-West, North-East
 Exposition 1 = Nord, Nord-Ouest, Nord-Est
 Exposição 2 = Sul, Sudeste, Sudoeste
 Exposure 2 = South, South-East, South-West
 Exposition 2 = Sud, Sud-Est, Sud-Ouest

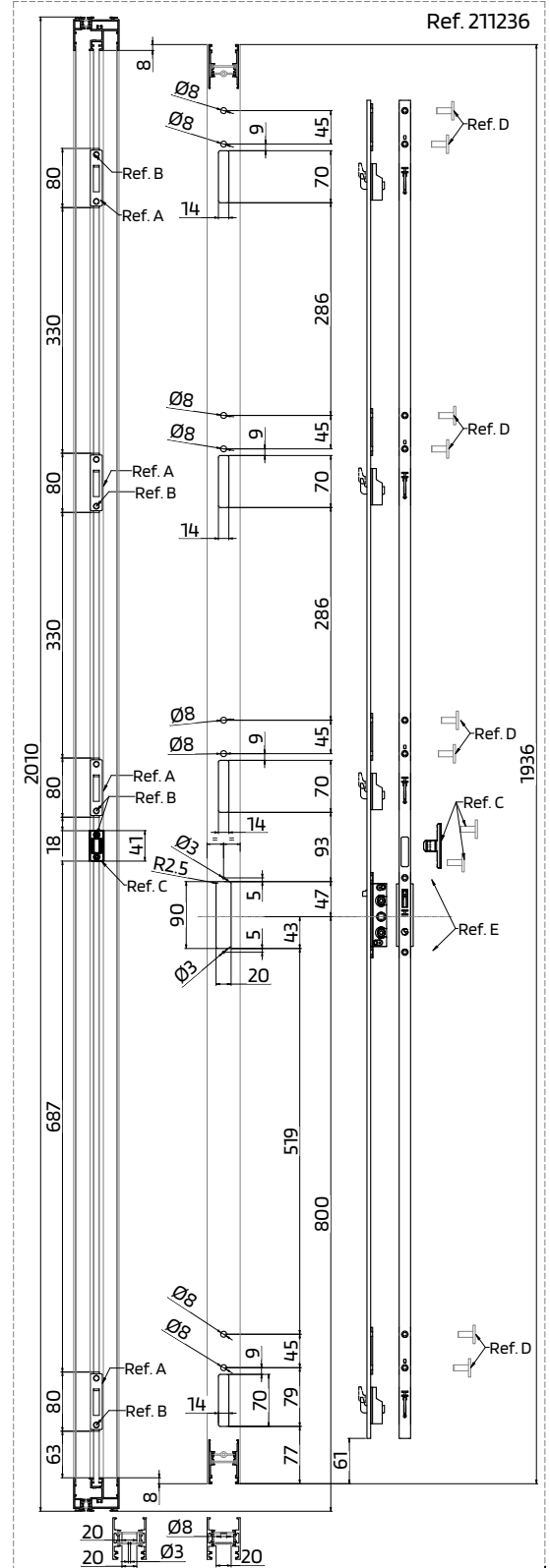
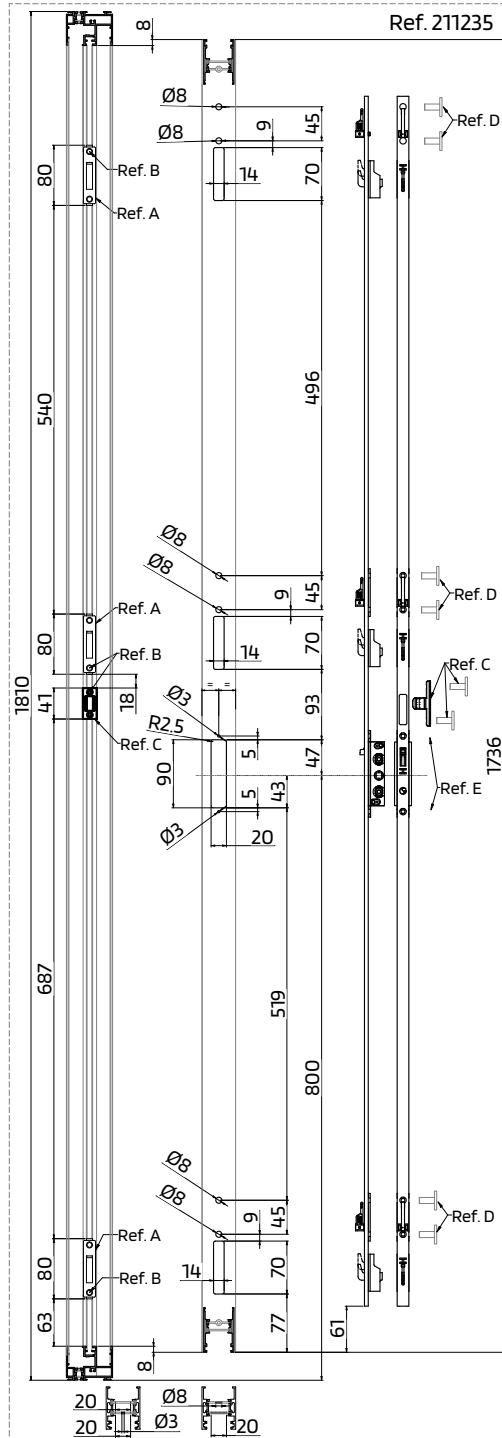



MAQUINAÇÕES PARA FERRAGEM MULTIPONTO ALU MAC
 ALU MAC MULTIPOINT HARDWARE MACHINING
 USINAGE POUR FERRURE MULTIPOINT ALU MAC

211233 MULTIPONTO ALU MAC 600 (2P)
 211234 MULTIPONTO ALU MAC 1000 (2P)
 211235 MULTIPONTO ALU MAC 1600 (3P)
 211236 MULTIPONTO ALU MAC 1800 (4P)
 Material: Inox | Acabamento: Inox

211036 PONTO-FECHO ALU MAC 200 (1P)
 Material: Inox | Acabamento: Inox

212289 CONJ. CENTRADOR P/ FERR. ALU
 Para centrar vãos JTI JT-Slim, com ferragem ALU (aplicar no aro fixo). Não inclui fixação para contra-fecho (ref. 212455 - 2uni)

202330 (para perfis aro fixo)
 202331 (para perfis J771 e J772)
 Para ferragens multiponto ALU
 Material: Inox | Acabamento: Inox

290077 PARAF. DIN7982 PH 4,2x16 INOX A2
 Para aplicar os topos folha OR-PV
 Material: Inox | Acabamento: Inox

200817 200819 PUXADOR SLIM XS (Direito)
 PUXADOR SLIM XS (Esquerdo)
 Parafusos inclusos (Compatível com Multi ALU e S05 Acabamentos: Lacados e Anodizados)

290078 PARAF. DIN7982 PH 4,2x25 INOX A2
 Para aplicar os topos folha OR-PV
 Material: Inox | Acabamento: Inox

212373 CONJ. FIXAÇÃO JT-SLIM
 DIN7982 TORX 4,2x25 A2 UT-SLIM
 Para fixação das ferragens multiponto

212455 (para perfis aro fixo)
 212458 (para perfis J771 e J772)
 Para fixação dos contra-fechos ALU e AL
 Acabamentos: Inox (refs 212455/58) e Preto (ref 212455)

212291 CONJ. CENTRADOR P/ FERR. ALU PERFLILIG
 Para centrar vãos JTI JT-Slim com ferragem ALU (aplicar no perfil fixo). Não inclui fixação para contra-fecho (ref. 212458 - 2uni)

200959 200959 CREMONE MULT. DESVIADO DIR
 CREMONE MULT. DESVIADO ESQ
 Quadra 7mm | Compatível com Multi ALU e S05 Acabamento: Lacados

Ferragem SEM centrador
 Hardware WITHOUT centerer
 Ferrure SANS centreur

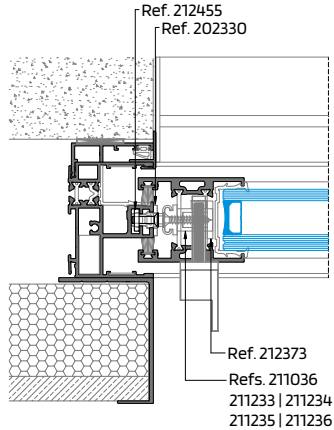

Ferragem COM centrador
 Hardware WITH centerer
 Ferrure AVEC centreur

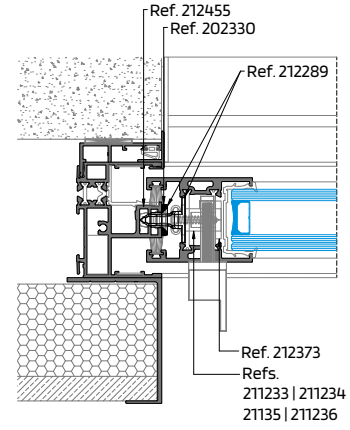

Estas peças devem ser coladas no perfil móvel
 These parts must be glued to the mobile profile
 Ces pièces doivent être collées au profilé mobile

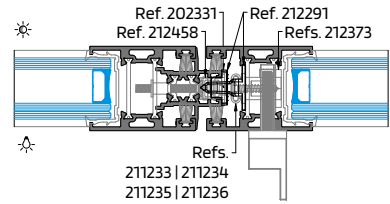
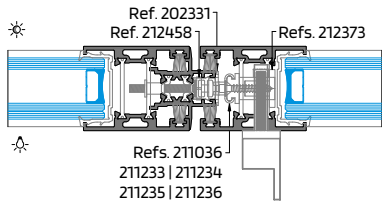

ACESSÓRIOS A CONSIDERAR POR FERRAGEM MULTIPONTOS ALU MAC:
 ACCESSORIES TO CONSIDER BY ALU MAC MULTIPOINT HARDWARE:
 ACCESSOIRES À CONSIDÉRER PAR FERRURE MULTIPOINT ALU MAC:

Ref.	MAC.200 (1P)	MAC.600 (2P)	MAC.1000 (2P)	MAC.1600 (3P)	MAC.1800 (4P)
	sem centrador without centerer sans centreur				
211036	1	-	-	-	-
211233 211234 211235 211236	-	1	1	1	1
200817 200818 ou ou or 200939 200959	1	1	1	1	1
212373	-	4	4	6	8
202330 (a) ou ou or 202331 (b)	1	2	2	3	4
212455 (a) ou ou or 212458 (b)	1	2	2	3	4
290078	2	2	2	2	2

(a) Para tipologias de aro fixo.
 For fixed frame typologies. | Pour les types de châssis fixes.
 (b) Para tipologias de encontro no mesmo rail e canto.
 For meeting on the same rail and corner typologies. | Pour les typologies de réunion sur le même rail et d'angle.

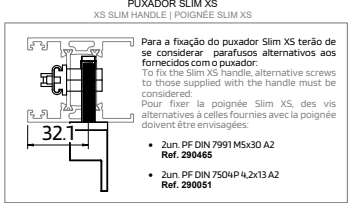
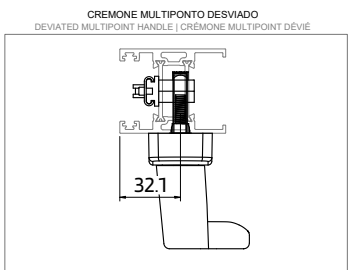

ACESSÓRIOS A CONSIDERAR POR FERRAGEM MULTIPONTOS ALU MAC:
 ACCESSORIES TO CONSIDER BY ALU MAC MULTIPOINT HARDWARE:
 ACCESSOIRES À CONSIDÉRER PAR FERRURE MULTIPOINT ALU MAC:

Ref.	MAC.600 (2P)	MAC.1000 (2P)	MAC.1600 (3P)	MAC.1800 (4P)
	com centrador with centerer avec centreur			
	<1500mm	<1500mm	>2000mm	>2000mm
211233 211234 211235 211236	1	1	1	1
200817 200818 ou ou or 200939 200959	1	1	1	1
212373	4	4	6	8
202330 (a) ou ou or 202331 (b)	2	2	3	4
212455 (a) ou ou or 212458 (b)	3	3	5	7
290078	2	2	2	2
212289 (a) ou ou or 212291 (b)	1	1	3	4



MONTAGEM DOS PERFIS ARO FIXO (CORTE 45°)
 FIXED FRAME PROFILES ASSEMBLY (45° CUT)
 ASSEMBLAGE DES PROFILÉS DORMANT (COUPE 45°)

Aplicar silicone à cor do perfil ou silicone neutro na zona das esquadrias. **Seguir este procedimento em todos os perfis de aro fixo PT.**
 Apply silicone in the same color as the profiles or neutral silicone in the frame's areas. **Follow this procedure in all fixed frame PT profiles.**
 Appliquer du silicone sur la couler des profilés ou du silicone neutre dans la zone des cadres. **Suivre cette procédure sur tous les profilés dormant PT.**

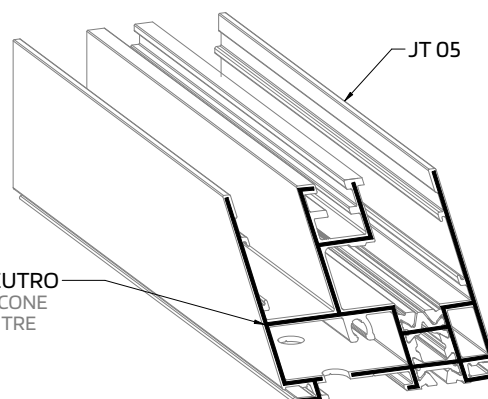
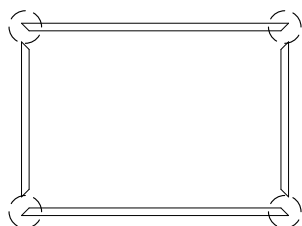

SILICONE NEUTRO
 NEUTRAL SILICONE
 SILICONE NEUTRE



Antes de colocar os esquadros, encher as câmaras dos perfis fixos com silicone neutro, de modo a ficarem seladas. **Seguir este procedimento em todos os perfis de aro fixo PT, apenas na zona inferior do caixilho.**

Before placing the corner cleats, the fixed frame profiles chambers must be filled with neutral silicone, in order to be sealed. **Follow this procedure in all the fixed frame PT profiles, only in the lower zone of the frame.**

Avant d'installer les équerres, les chambres des profilés dormants doivent être remplies de silicone neutre afin d'être scellées. **Suivre cette procédure sur tous les profilés dormant PT, uniquement dans la zone inférieure du cadre.**

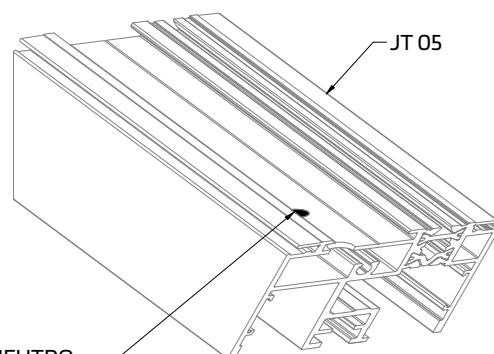
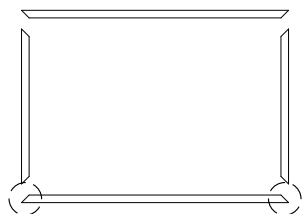

SILICONE NEUTRO
 NEUTRAL SILICONE
 SILICONE NEUTRE





MONTAGEM DOS PERFIS ARO FIXO PT (CORTE 90°)

PT FIXED FRAME PROFILES ASSEMBLY (90° CUT)

ASSEMBLAGE DES PROFILÉS DORMANT PT (COUPE 90°)

Colocação do conjunto de estanqueidade para corta-vento nos aros fixos.

Central waterproofing pile seal kit placing in fixed frames.

Mise en place du kit brosse centrale d'étanchéité pour les cadres dormants.

Colocar o Conjunto de estanqueidade, apenas em baixo, no cruzamento das folhas onde posteriormente levará o perfil PVC L e os corta-ventos. **Seguir este procedimento em todos os perfis de aro fixo PT.**

Place the central waterproofing pile seal kit, only on the bottom, at the intersection of the sashes where later the U PVC, L PVC profile and the central gasket will be. **Follow this procedure in all fixed frame profiles PT.**

Placer le kit brosse centrale d'étanchéité à l'intersection des vantaux, juste en bas, où prendront plus tard le profilé PVC U, PVC L et les brosses centrales d'étanchéité. **Suivre cette procédure sur tous les profilés dormant PT.**

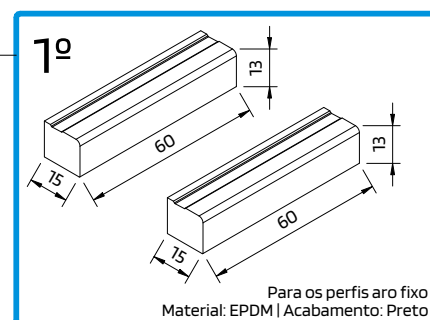
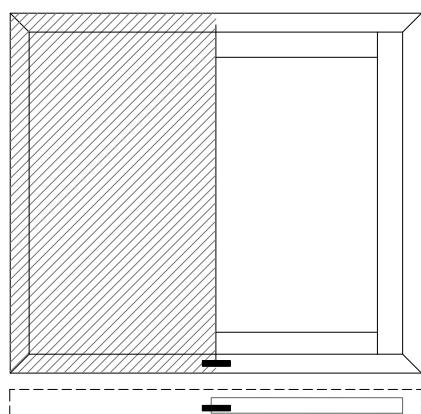

212337

CONJ. ESTANQUEIDADE
CORTA-VENTO JT

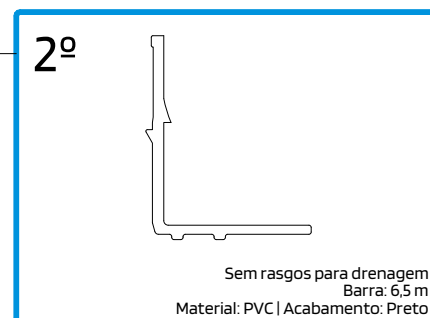

215311

PERFIL PVC L MONORAIL JT

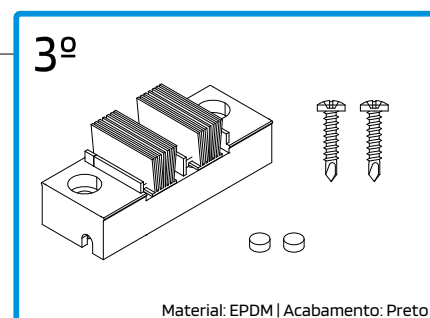
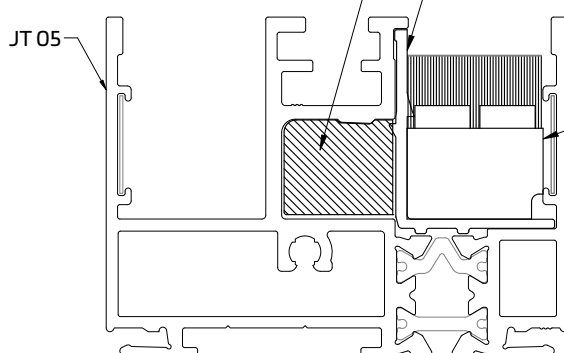

213303

CORTA VENTO JT FIXO



MONTAGEM DO PERFIL ARO FIXO PT (CORTE 45°)
PT FIXED FRAME PROFILE ASSEMBLY (45° CUT)
ASSEMBLAGE DE PROFILÉ DORMANT PT (COUPE 45°)

Colocação dos perfis PVC L nos aros fixos.

L PVC profile placing in fixed frames.
 Mise en place du profilé PVC L sur le cadre dormant.

Antes de fechar as esquadrias com os esquadros, colocar o perfil de PVC L

Before closing the frames with the squares, place the PVC L profile
 avant de fermer les châssis avec les équerres, placez le profilé en PVC L

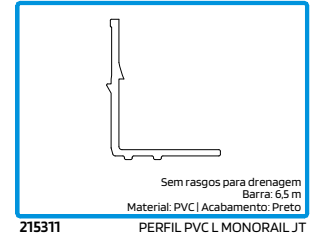
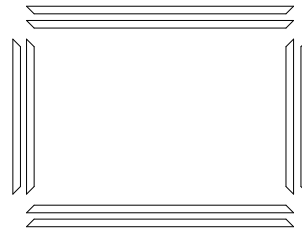
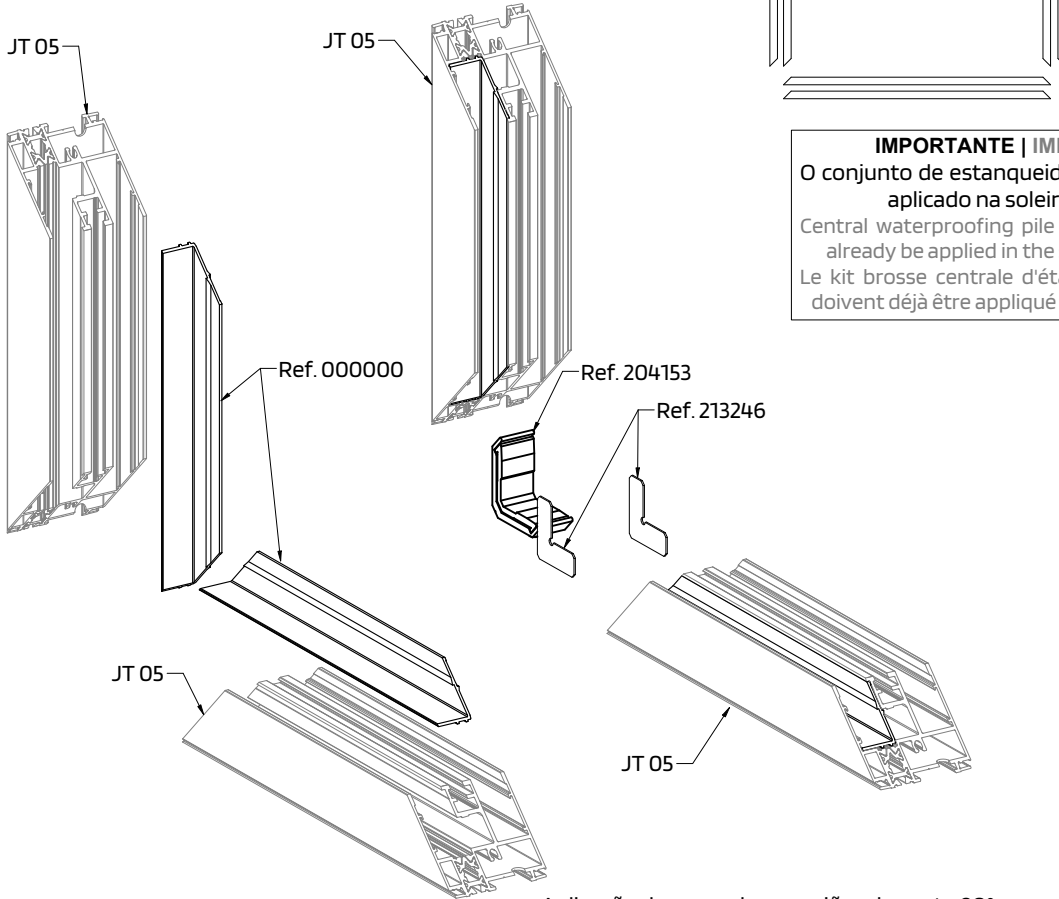

IMPORTANTE | IMPORTANT | IMPORTANT:
 O conjunto de estanqueidade (no aro fixo) já deverá estar aplicado na soleira antes desta operação.
 Central waterproofing pile seal kit (in the fixed frame) must already be applied in the sill profile before this operation.
 Le kit brosse centrale d'étanchéité (dans le cadre dormant) doivent déjà être appliqué sur le seuil avant cette opération.

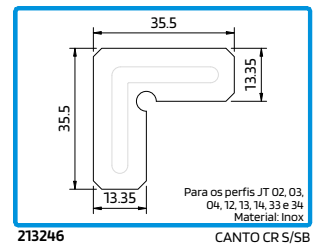
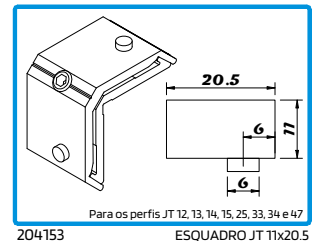

Aplicação do esquadros e uniões de canto 90° no aro fixo - tipologias de canto 90°
 Corner cleats and 90° corner unions applying in fixed frame - 90° corner typologies
 Application des équerres et les angles d'union 90° sur le cadre dormant - typologies en angle 90°

Montagem de aros fixos, em tipologias de canto 90°.
 Fixed frames assembly, in 90° corner typologies.
 Montage de cadres dormant, en types d'angle à 90°.

Os perfis PVC L são cortados a 45°
 PVC L profiles are cut at 45°.
 Les profilés PVC L sont coupés à 45°

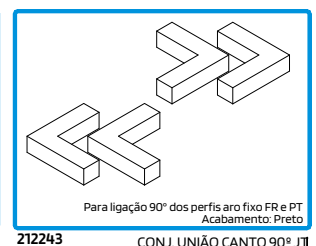
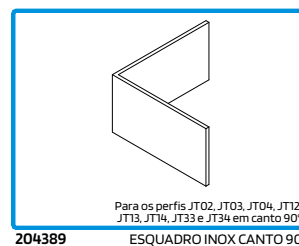
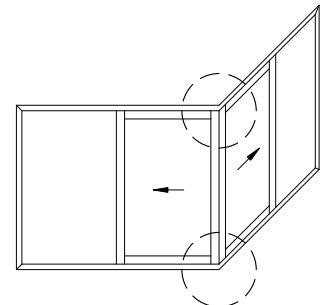
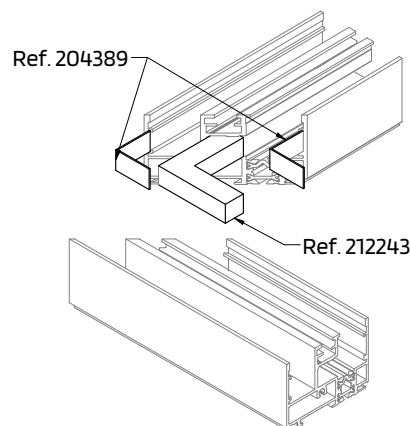
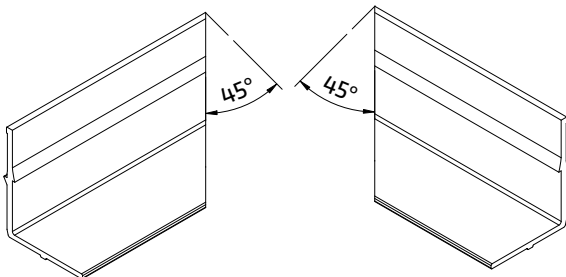



MONTAGEM DOS PERFIS ARO FIXO PT (CORTE 90°)
 PT FIXED FRAME PROFILES ASSEMBLY (90° CUT)
 ASSEMBLAGE DES PROFILÉS DORMANT PT (COUPE 90°)

Colocação dos corta-ventos nos aros fixos.

Central waterproofing pile seal placing in fixed frames.

Placement des brosses centrale d'étanchéité sur les cadres dormants.

Em primeiro colocar os corta-ventos na soleira. Os corta-ventos da padieira deverão ser colocados depois das folhas de correr já estarem aplicadas. Seguir este procedimento em todos os perfis de aro fixo PT.

First place the lower central waterproofing pile seals on the sill. The intel central waterproofing pile seals must be placed after the sliding sashes are already applied. Follow this procedure in all fixed frame PT profiles.

En premier placer les brosses centrale d'étanchéité sur le seuil. Les brosses centrale d'étanchéité sur le linteau doivent être placés après que les vantaux coulissant sont déjà appliquées. **Suivre cette procédure sur tous les profilés dormant PT.**

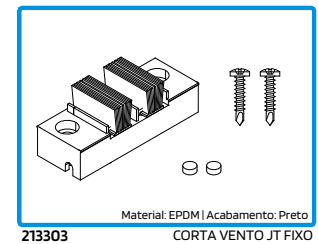
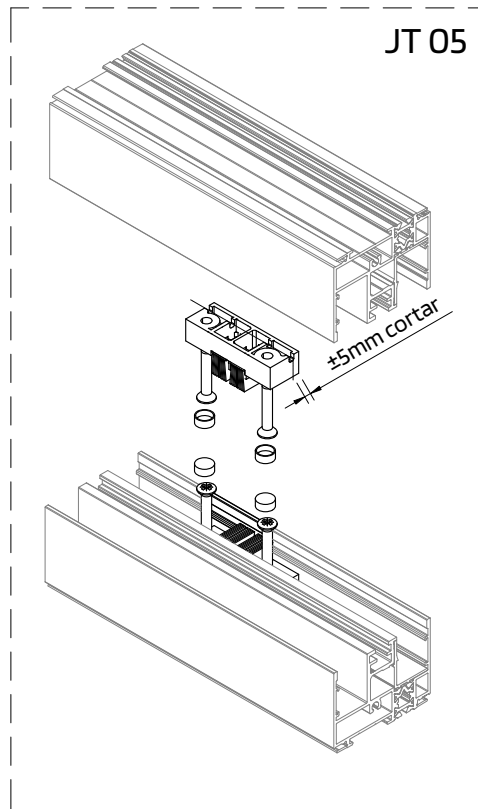
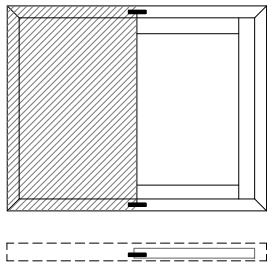

O Corta vento JT-Fixo (Ref. 213303) será utilizado provisoriamente até o Corta-vento específico para esta solução ser oportunamente fabricado. Para tal, o corta vento JT-Fixo terá de ser cortado em 5mm, conforme o esquema apresentado.

The JT-Fixo waterproofing pile seal (Ref. 213303) will be used temporarily until the specific waterproofing pile seal for this solution is manufactured in due course. Therefore, the JT-Fixo waterproofing pile seal will need to be cut by 5 mm, as shown in the diagram.

Le brosse centrale d'étanchéité JT-Fixo (réf. 213303) sera utilisé à titre provisoire jusqu'à ce que le brosse centrale d'étanchéité spécifique à cette solution soit fabriqué en temps voulu. Par conséquent, le brosse centrale d'étanchéité JT-Fixo devra être raccourci de 5 mm, comme indiqué sur le schéma

Aplicar o corta-vento canto 90° JT no aro fixo.

Apply the 90° corner insulation gasket in the fixed frame.

Appliquer le brosse d'étanchéité angle 90°.

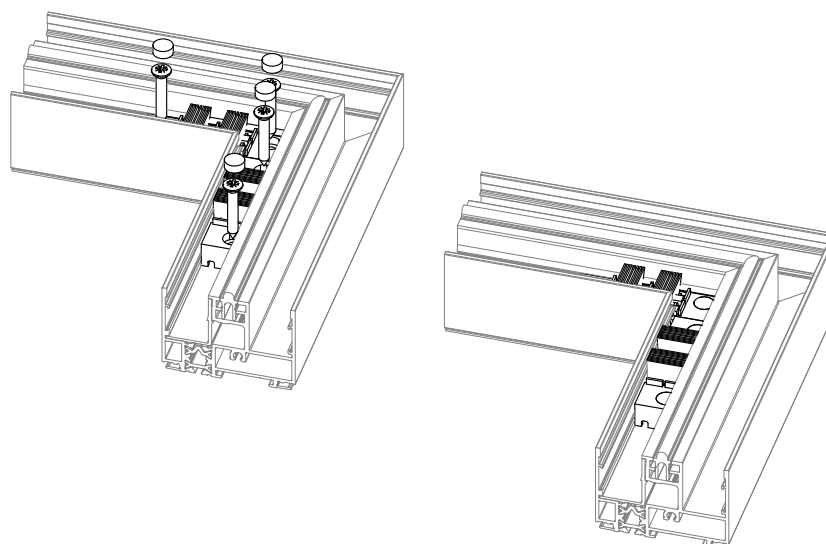



MONTAGEM DOS PERFIS ARO FIXO PT (CORTE 90°)
 PT FIXED FRAME PROFILES ASSEMBLY (90° CUT)
 ASSEMBLAGE DES PROFILÉS DORMANT PT (COUPE 90°)

Colocação de goteiras nos aros fixos.
 Drips placing in fixed frames.
 Placement des clapets sur les cadres dormants.

Colocar as goteiras pelo exterior do perfil e fixá-las com pontos de cola. **Seguir este procedimento em todos os perfis de aro fixo PT.**
 Place the drips from the outside of the profile and fix them with glue points. **Follow this procedure in all PT fixed frame profiles.**
 Placer les lapets à volet à l'extérieur du profilé et fizer-les avec des points de colle. **Suivre cette procédure sur ous les profilés dormant PT.**

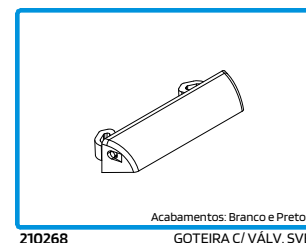

Tipologias JT-Oculta

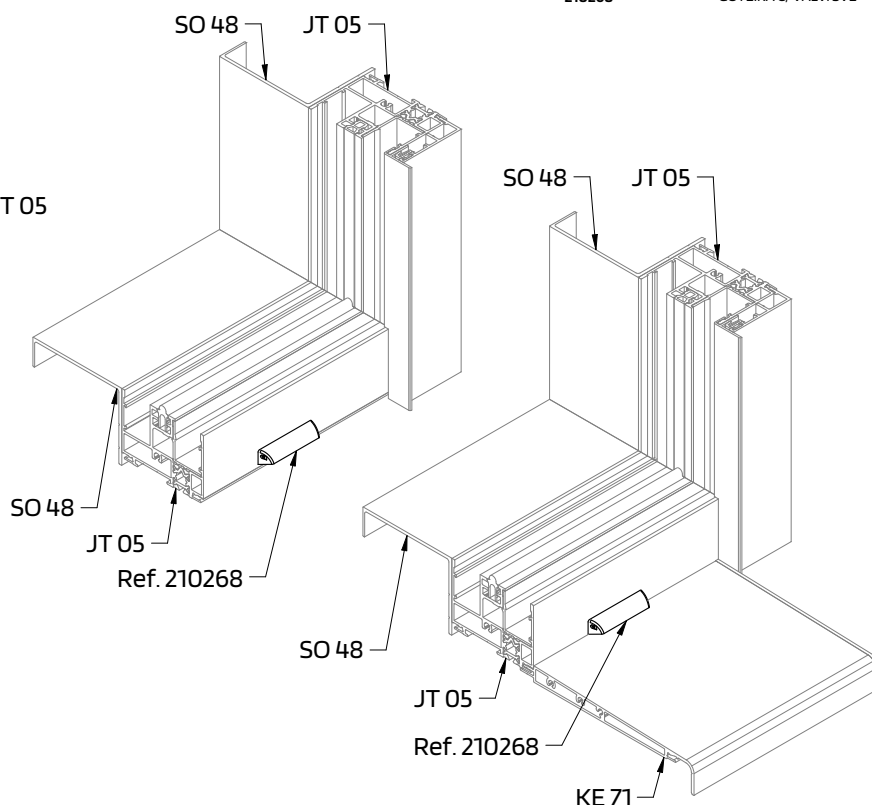
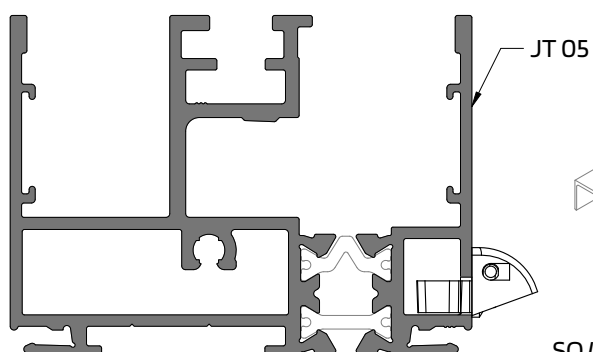

Tipologias JT Oculta com caleira

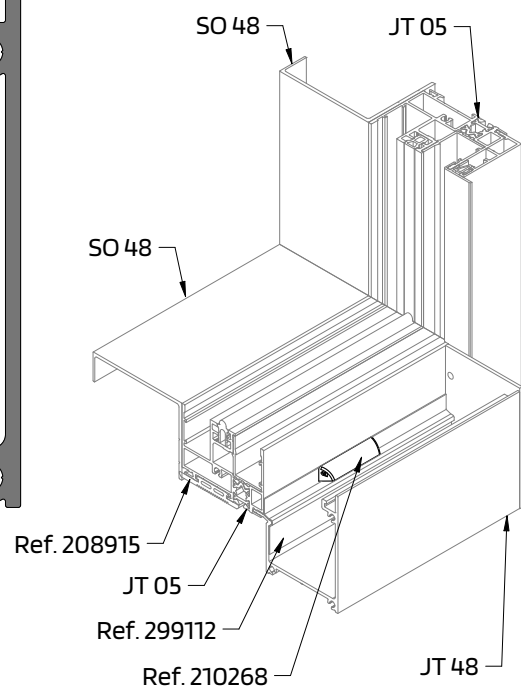
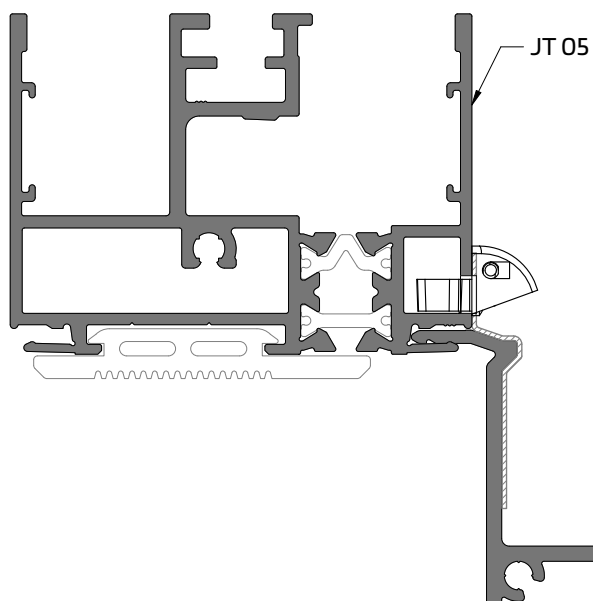



CORTE DOS TOPOS PARA AS TIPOLOGIAS COM CALEIRA
 CUTTING THE TOPS FOR TYPES WITH GUTTERS
 COUPE DES EXTRÉMITÉS POUR LES TYPES AVEC GOUSSIÈRE

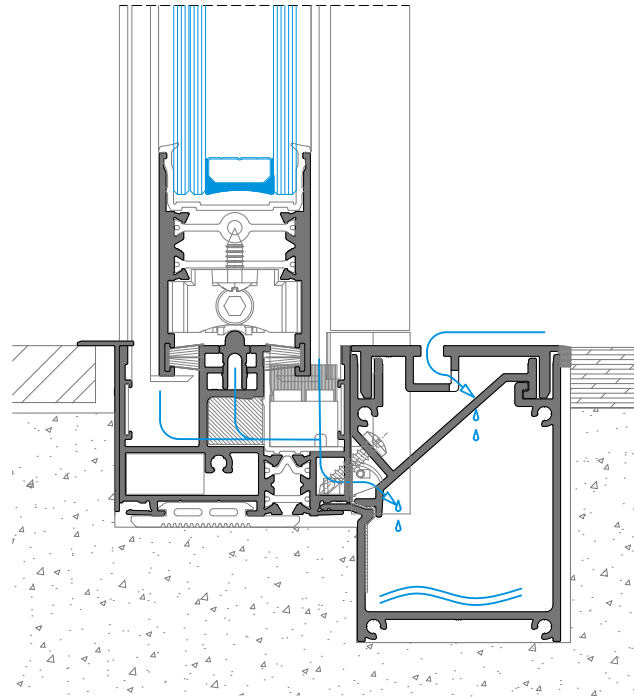
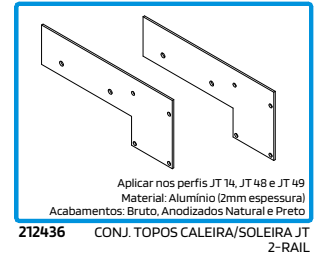

Corte com disco de corte
 Cut with cutting disc
 Coupe avec disque de coupe

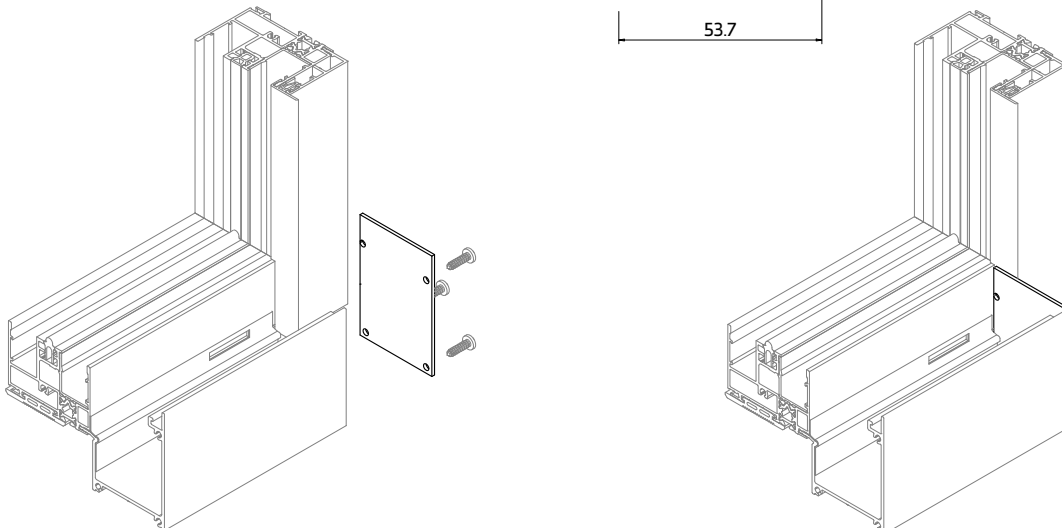
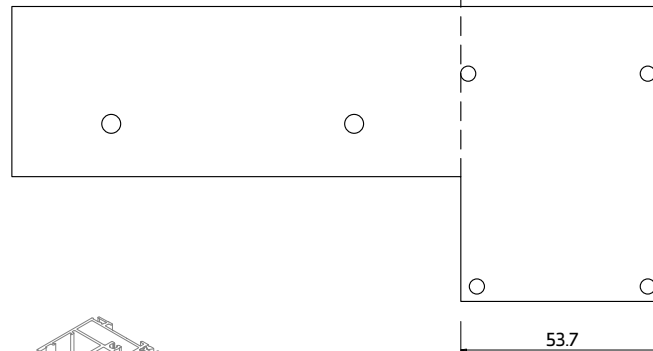



MONTAGEM DE ACESSÓRIOS

ACCESSORIES ASSEMBLY
ASSEMBLAGE D'ACCESSOIRES

Montagem do Conjunto de Guias Superiores JT

Assembly of JT Upper Guides Kit

Assemblage de Kit des Guides Supérieures JT

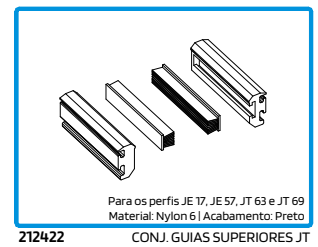
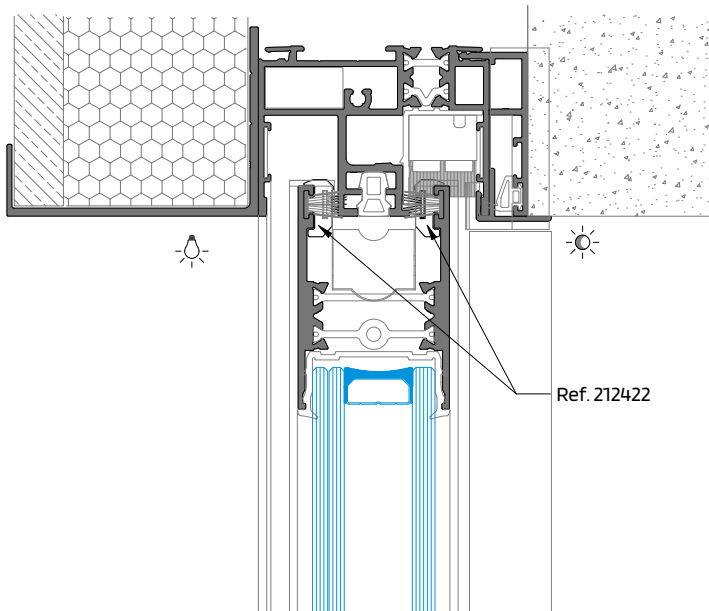

IMPORTANTE | IMPORTANT | IMPORTANT:

As Guias devem ser aplicadas nas travessas superiores antes de fechar o aro móvel
The Guides must be applied on the upper transoms before closing the mobile frame
Les Guides doivent être appliqués sur les traverses supérieures avant de fermer le cadre ouvrant

Quantidade a aplicar por folha
Quantity to apply per sash | Quantité à appliquer par vantail

Largura da folha (Lf) Sash width Largeur de la ventail	JT	JT Slim
De 0,00-1,00m From 0,00-1,00m De 0,00-1,00m	1	1
De 1,00-2,00m From 1,00-2,00m De 1,00-2,00m	2	2

$Lf \leq 1,00 \text{ m}$

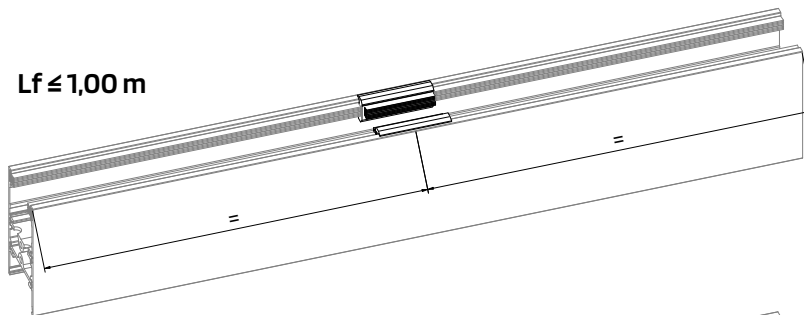

$1,00 \text{ m} \leq Lf \leq 2,00 \text{ m}$

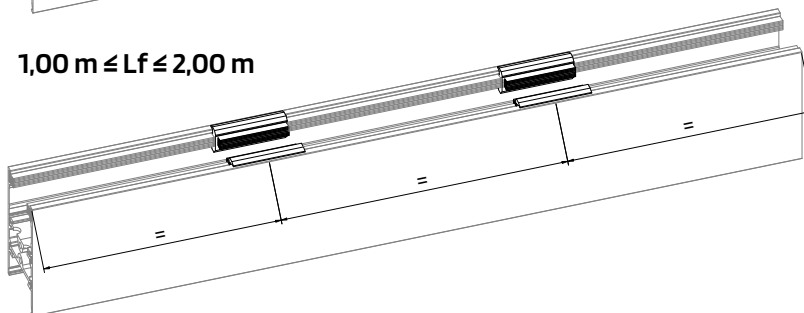

Ferragem Multiponto
Multipoint Hardware
Ferrure Multipoint



MONTAGEM DE ACESSÓRIOS

ACCESSORIES ASSEMBLY
ASSEMBLAGE D'ACCESSOIRES

Montagem do Conjunto de Guias Superiores JT
Assembly of JT Upper Guides Kit
Assemblage de Kit des Guides Supérieures JT

JT Standard

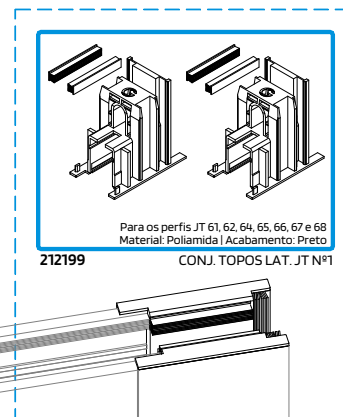
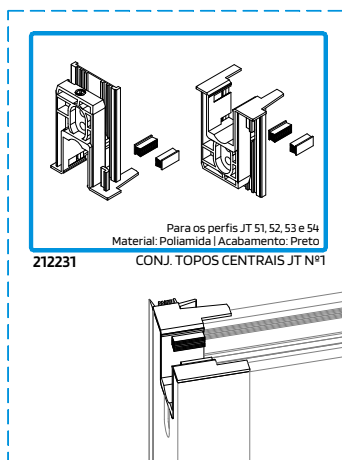
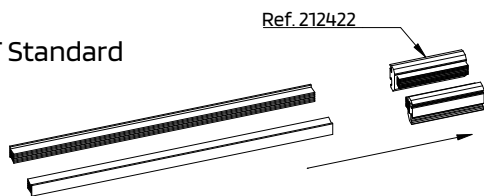

JT Slim

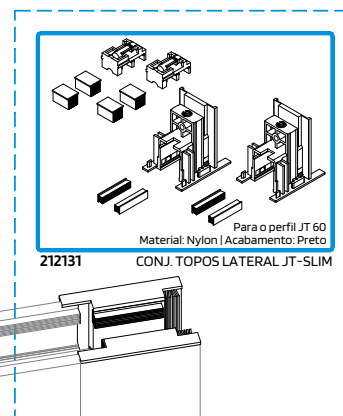
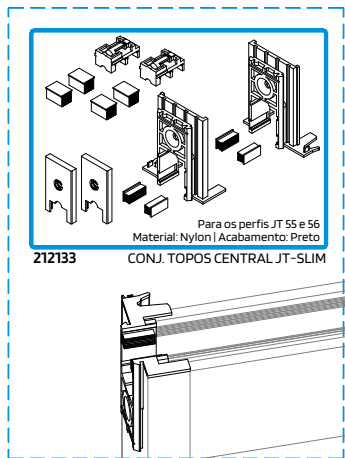
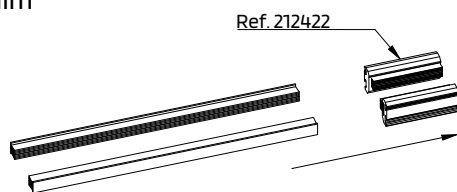



SEQUÊNCIA DE MONTAGEM DO CAIXILHO

FRAME ASSEMBLY SEQUENCE

SÉQUENCE DE MONTAGE DU CHÂSSIS

1 - Aplicar o perfil PVC L monorail JT (Ref. 215311) antes de fechar o caixilho.

Apply the JT PVC L monorail profile (Ref. 215311) before closing the frame.
Appliquer le profilé PVC L monorail JT (Ref. 215311) avant de fermer le cadre.

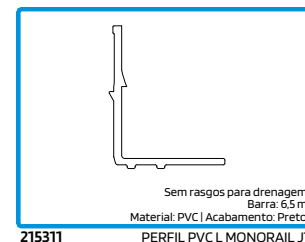
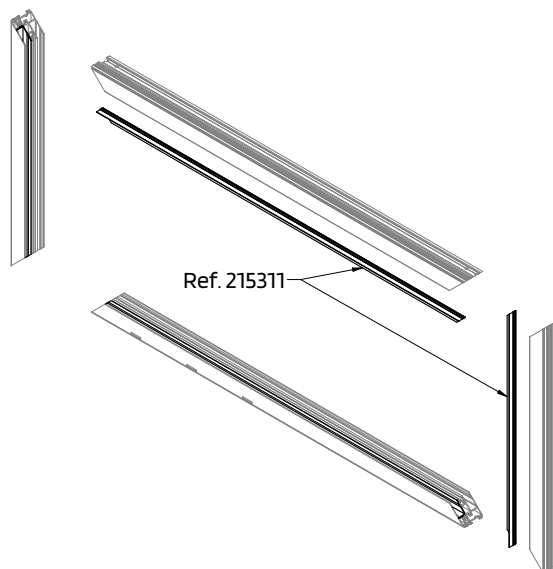

2 - Aplicar os esquadros (Ref. 204153 e Ref. 213246) e fechar o caixilho.

Apply the corner cleats (Ref. 204153 and Ref. 213246) and close the frame.
Appliquez des équerres (Ref. 204153 et Ref. 213246) et fermer le cadre.

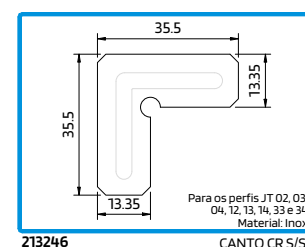
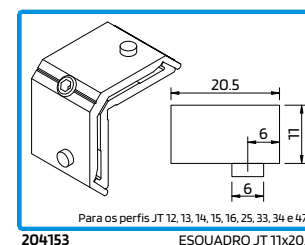
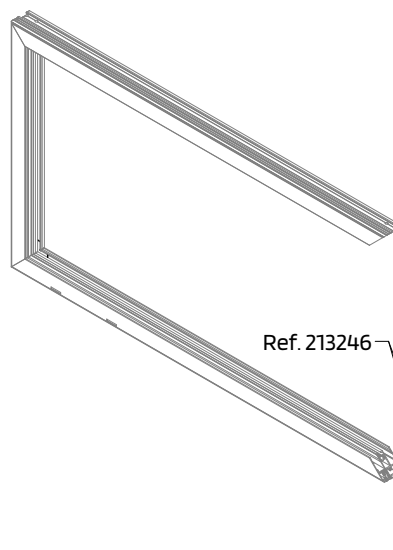

3 - Aplicar primeiro a junta de estanquidade (Ref. 208257) e os cantos de alinhamento (Ref. 213017) no perfil vertical JT 80 e colocá-los no caixilho, depois colocar os perfis JT 80 horizontais.

First apply the sealing gasket (208257) and the alignment corners (213017) to the JT 80 vertical profile and place it in the frame, then place the JT 80 horizontal profiles.

Appliquez d'abord le joint d'étanchéité (208257) et les coins d'alignement (213017) sur le profilé vertical JT 80 et placez-le dans le cadre, puis placez les profilés JT 80 horizontaux.

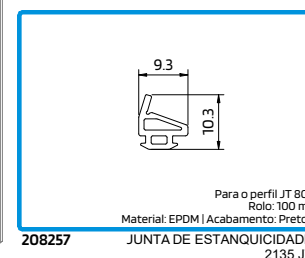
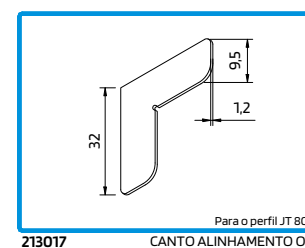
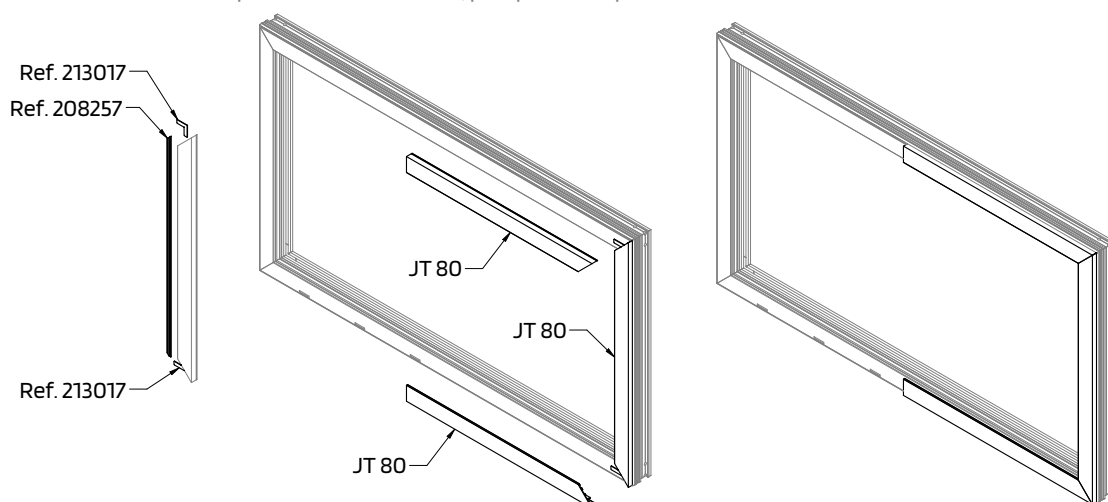



SEQUÊNCIA DE MONTAGEM DO CAIXILHO

FRAME ASSEMBLY SEQUENCE

SÉQUENCE DE MONTAGE DU CHÂSSIS

- 4 - Colocar as juntas de estanquidade horizontais (Ref. 208257) nos perfis JT 80. A seguir colocar pontos de cola para a fixação do conjunto de topos inferior e superior JT (Ref. 212441).

Place the horizontal sealing gaskets (Ref. 208257) on the JT 80 profiles. Then apply dots of adhesive to secure the lower and upper JT end pieces (Ref. 212441).

Placer les joints d'étanchéité horizontaux (Ref. 208257) sur les profilés JT 80. Appliquer ensuite des points de colle pour fixer l'ensemble des embouts inférieurs et supérieurs JT (Ref. 212441).

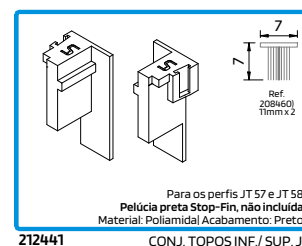
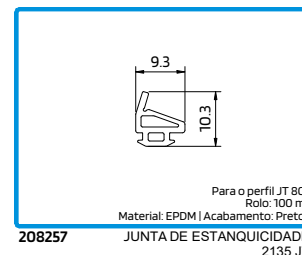
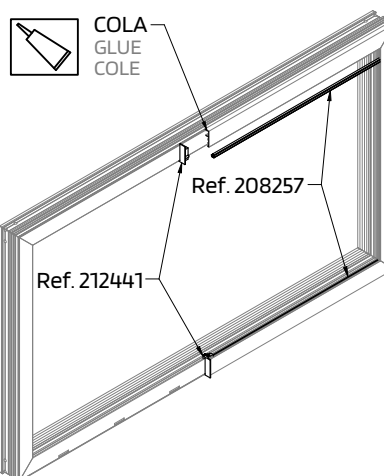

- 5 - Aplicar as juntas de estanquidade (Ref. 208257) e o canto de alinhamento (Ref. 213017) nos perfis JT 80 vertical e horizontal e colocá-los no caixilho.

Apply the sealing gaskets (Ref. 208257) and the alignment corner (Ref. 213017) to the JT 80 vertical and horizontal profiles and place them in the frame.

Appliquer les joints d'étanchéité (Ref. 208257) et le coin d'alignement (Ref. 213017) sur les profilés JT 80 verticaux et horizontaux et les placer dans le cadre.

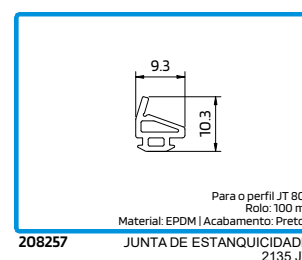
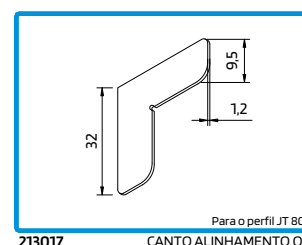
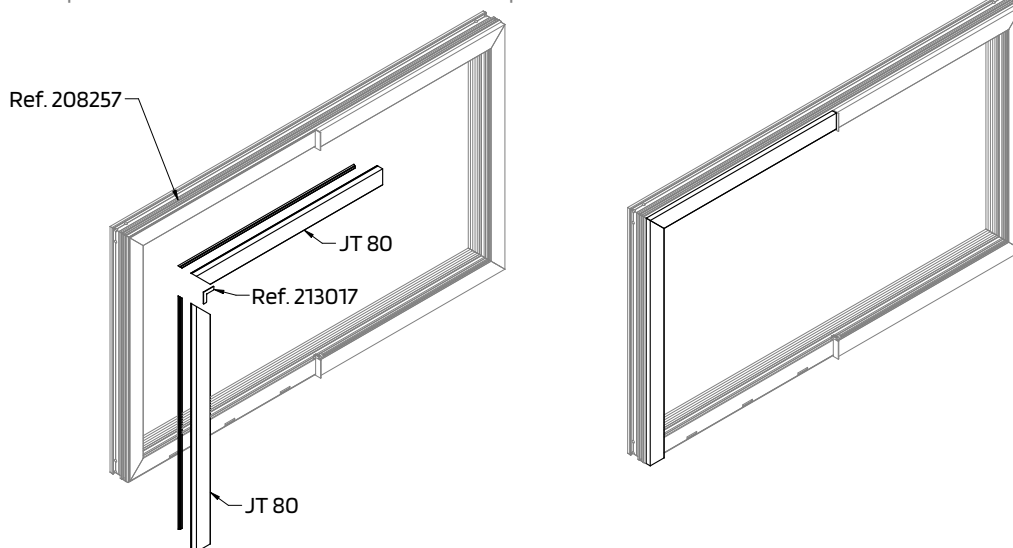

- 6 - Aplicação dos contra-ferchos (Ref. 202330) e o perfil guia JT 87.

Application of counter-latches (Ref. 202330) and JT 87 guide profile.

Application des contre-fermetures (Ref. 202330) et du profilé de guidage JT 87.

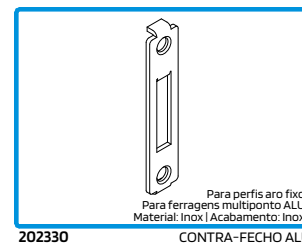
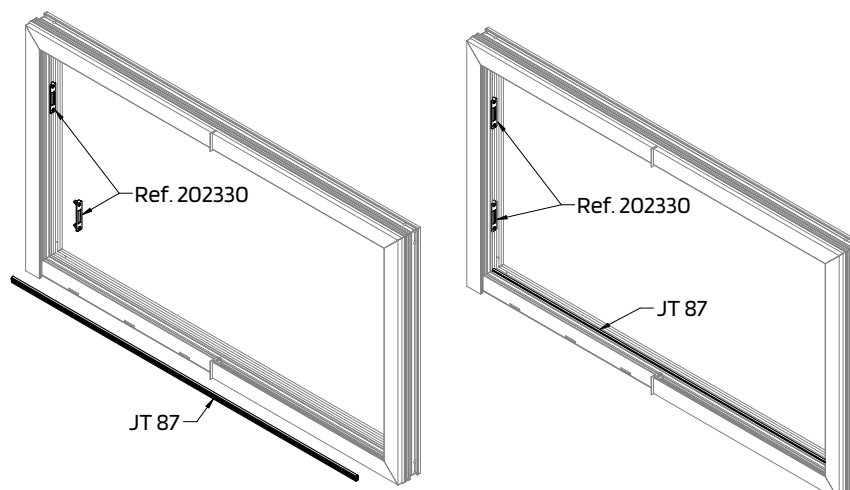



SEQUÊNCIA DE MONTAGEM DO CAIXILHO
FRAME ASSEMBLY SEQUENCE
SÉQUENCE DE MONTAGE DU CHÂSSIS

7 - Da parte interior do caixilho, fixar os perfis SO 48 com os parafusos (Ref. 290472).

From the inside of the frame, fix the SO 48 profiles with screws (Ref. 290472).

De l'intérieur du cadre, fixez les profilés SO 48 à l'aide de vis (réf. 290472).

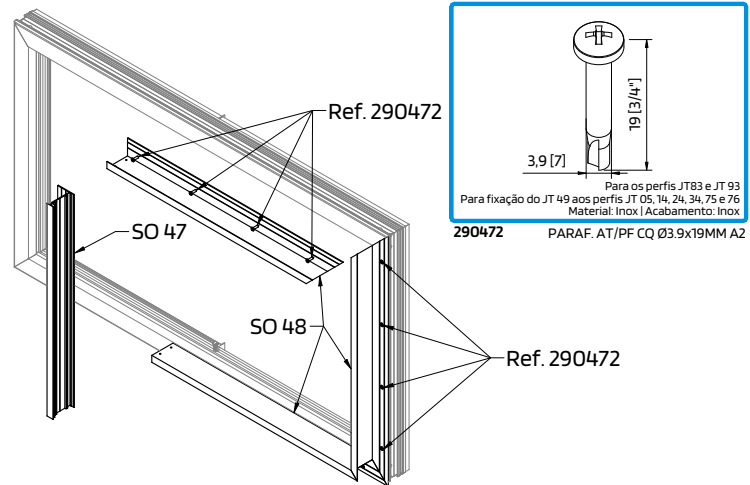

8 - Colocar o perfil SO 47 e fixar com os parafusos (Ref. 290262).

Place the SO 47 profile and fix with screws (Ref. 290262)

Placer le profilé SO 47 et le fixer à l'aide des vis (Ref. 290262).

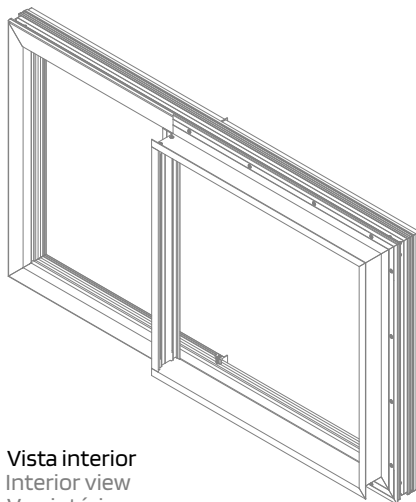
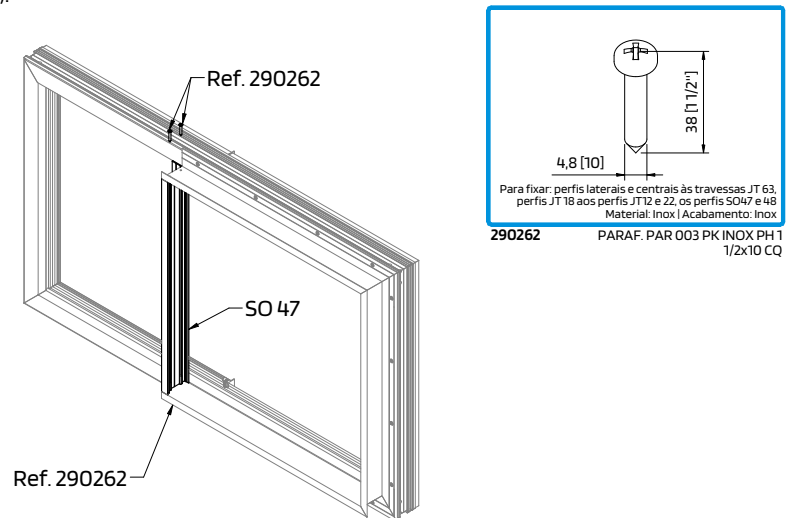

Vista interior
 Interior view
 Vue intérieure

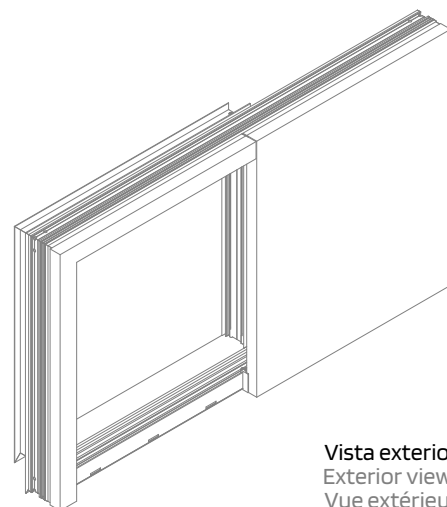

Vista exterior
 Exterior view
 Vue extérieure



SEQUÊNCIA DE MONTAGEM DO CAIXILHO

FRAME ASSEMBLY SEQUENCE

SÉQUENCE DE MONTAGE DU CHÂSSIS

Os passos seguintes são comuns para os 2 tipos de tipologias monorail JT Slim e JT Standard.

The following steps are common to both types of monorail systems: JT Slim and JT Standard.

Les étapes suivantes sont communes aux deux types de monorails JT Slim et JT Standard.

9 - Colocar a pelúcia (Ref. 208469) e a junta central 2197 (Ref. 208351) no perfil JT 58 e colocar no caixilho fixo.

Place the pile seal (Ref. 208469) and the central gasket 2197 (Ref. 208351) on the JT 58 profile and place it on the fixed frame.

Placer la joint brosse (Ref. 208469) et la joint central 2197 (Ref. 208351) dans le profilé JT 58 et les placer dans le cadre fixe.

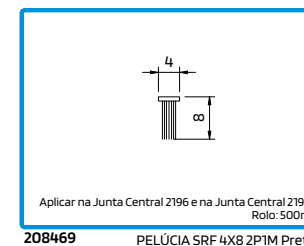
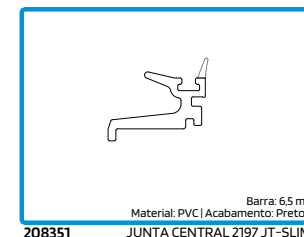
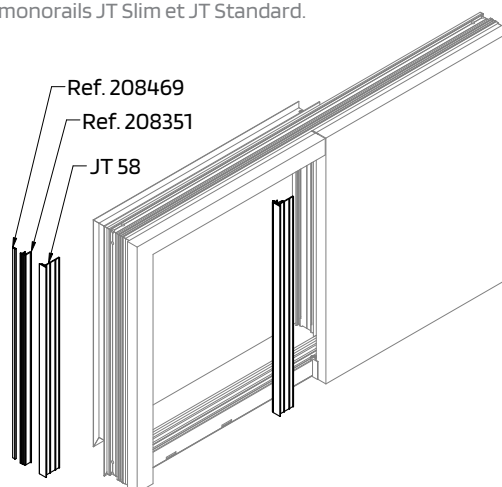

10 - Fixar o perfil JT 58 com os acessórios à parede exterior com parafusos e buchas.

Fix the JT 58 profile with the accessories to the exterior wall using screws and plugs.

Fixer le profilé JT 58 avec les accessoires au mur extérieur à l'aide de vis et de chevilles.

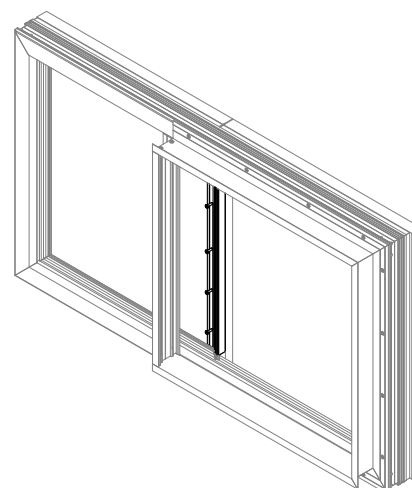

11 - A junta tapa canal 2116 (Ref. 208348 (a)), só será aplicada com a colocação da folha móvel e com os contra fechos (Ref. 202330) na sua posição final. As outras 2 juntas (Ref. 208348) serão aplicadas antes de colocar a folha móvel no caixilho.

The channel cover gasket 2116 (Ref. 208348 (a)) will only be fitted once the mobile sash has been fitted and the counter locks (Ref. 202330) are in their final position. The other two gaskets (Ref. 208348) will be fitted before placing the mobile sash in the frame.

Le joint de canal 2116 (réf. 208348 (a)) ne sera appliqué qu'après la mise en place du vantail mobile et des contre-fermetures (réf. 202330) dans leur position finale. Les deux autres joints (réf. 208348) seront appliqués avant de placer le vantail mobile dans le cadre.

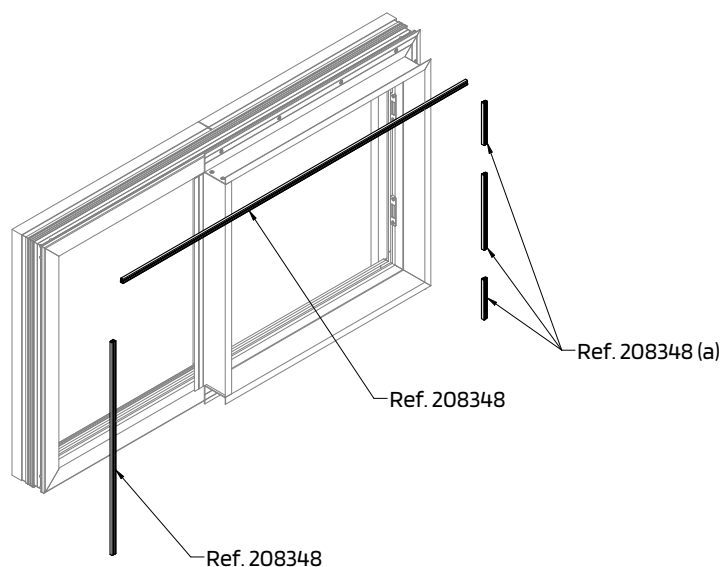



SEQUÊNCIA DE MONTAGEM DO CAIXILHO

FRAME ASSEMBLY SEQUENCE

SÉQUENCE DE MONTAGE DU CHÂSSIS

12 - Colocar o perfil interior SO 46 com a pelúcia 7x12mm (Ref. 208466), depois da folha móvel estar no caixilho.

Fit the SO 46 interior profile with the 7x12mm (Ref. 208466) pile seal, after the mobile sash is in the frame.

Placer le profilé intérieur SO 46 avec la joint brosse 7x12mm (Ref. 208466), une fois que l'ouvrant est dans le cadre.

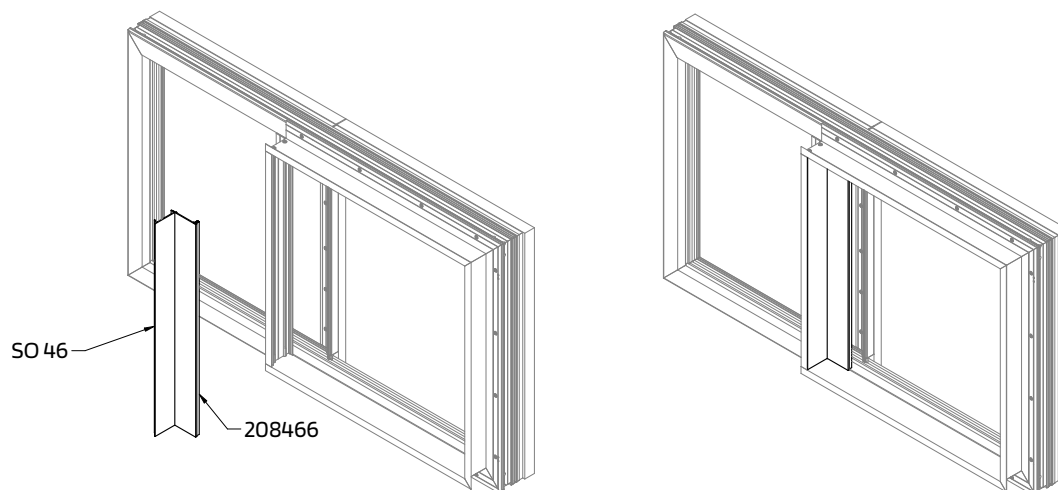
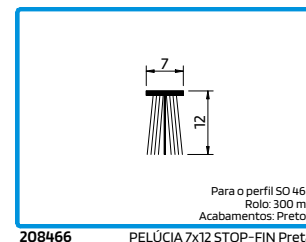

13 - Por fim, colocar primeiro o perfil de remate vertical JT 81 e depois o perfil de remate horizontal JT 81 no caixilho.

Lastly, first place the JT 81 vertical finishing profile and then the JT 81 horizontal finishing profile on the frame.

Pour finir, placer d'abord le profilé de finition vertical JT 81, puis le profilé de finition horizontal JT 81 sur le cadre.

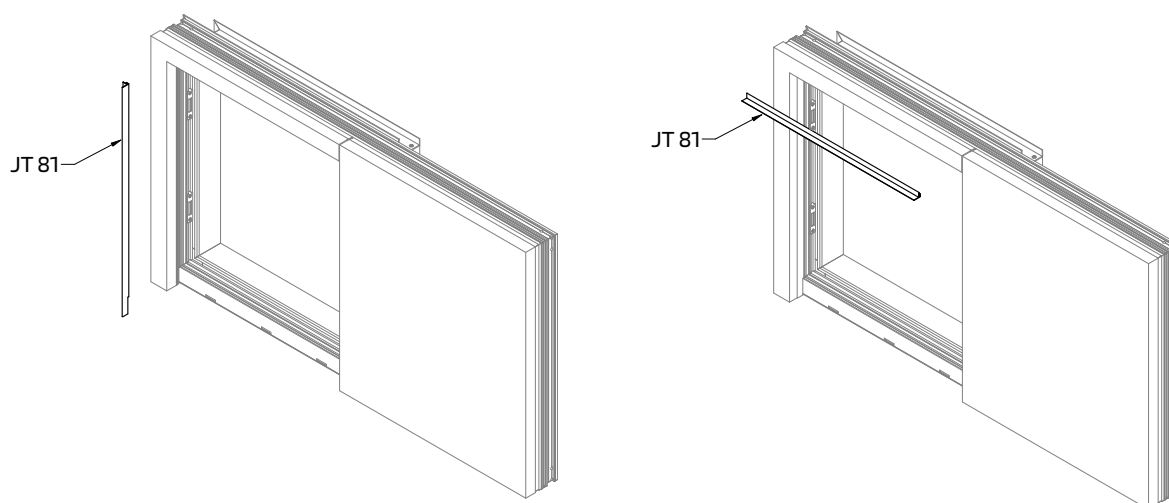

Importante: | Important: | Important:

Aplicar silicone à cor do perfil ou silicone neutro em todas as zonas de remate exteriores e interiores.

Apply silicone in the same colour as the profile or neutral silicone to all exterior and interior finishing areas.

Appliquer du silicone de la même couleur que le profilé ou du silicone neutre sur toutes les zones de finition extérieures et intérieures.



SEQUÊNCIA DE MONTAGEM DO CAIXILHO
FRAME ASSEMBLY SEQUENCE
SÉQUENCE DE MONTAGE DU CHÂSSIS

14 - Fixar os topos caleira ao perfil JT 48

Fix the Drainage channel end-caps to the JT 48 profile
 Fixer l'Embouts pour Gouttière de vidange au profilé JT 48

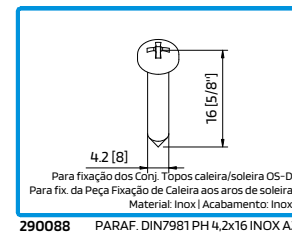
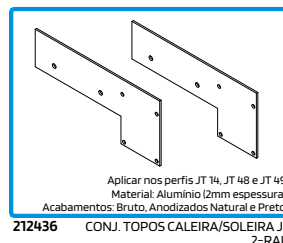
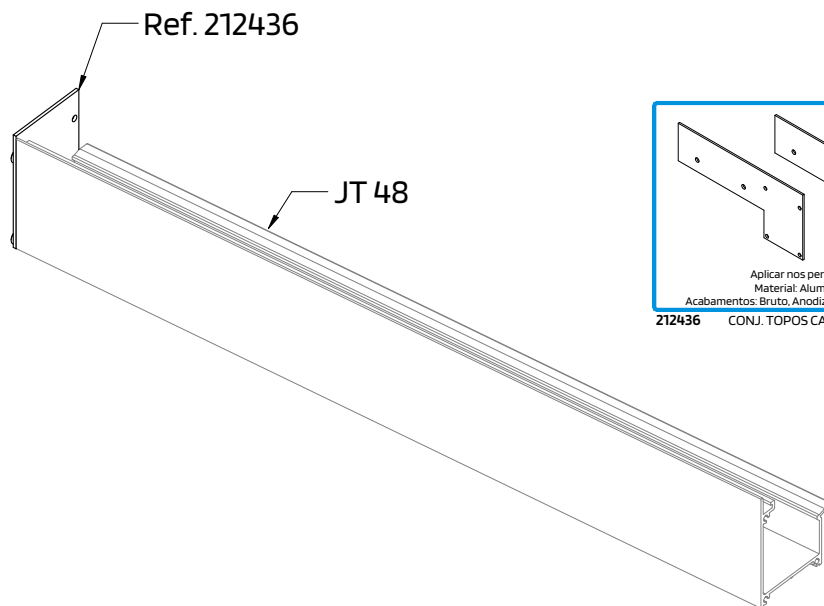

15 - Colocar a junta de remate (Ref. 208915) no caixilho
 Place the finishing joint (Ref. 208915) on the window frame.
 Placer le joint de finition (Ref. 208915) dans le cadre.

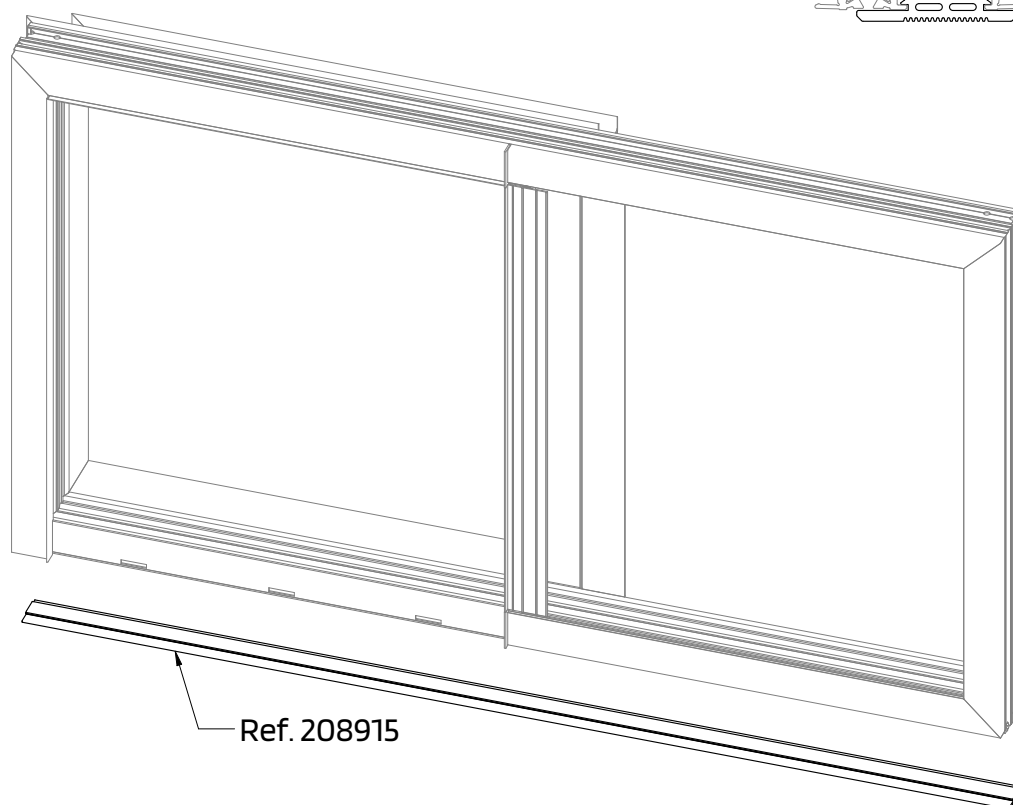
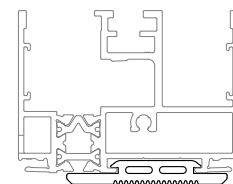
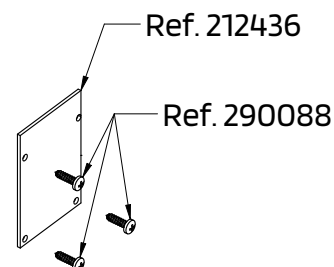
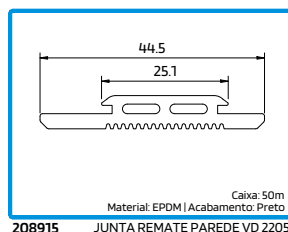



SEQUÊNCIA DE MONTAGEM DO CAIXILHO
FRAME ASSEMBLY SEQUENCE
SÉQUENCE DE MONTAGE DU CHÂSSIS

- 16- Encher a câmara com silicone neutro antes de colocar a caleira**
 Fill the chamber with neutral silicone before installing the gutter.
 Remplir la chambre avec du silicone neutre avant d'installer la gouttière.

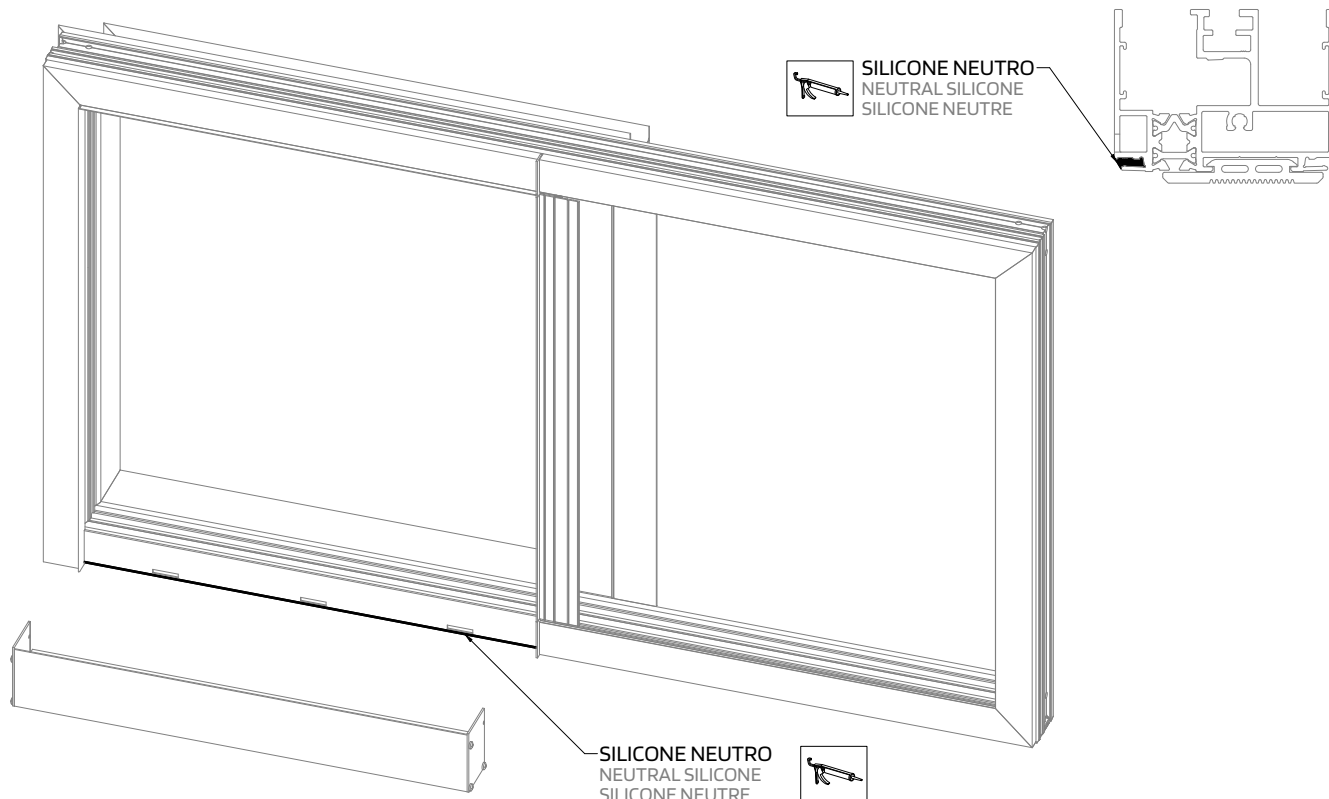

- 17 - Aplicar a membrana de selagem.**
 Apply the sealing membrane.
 Appliquer la membrane d'étanchéité.



299112 MEMBRANA SELAGEM 50MM (2M)

Ref. 299112

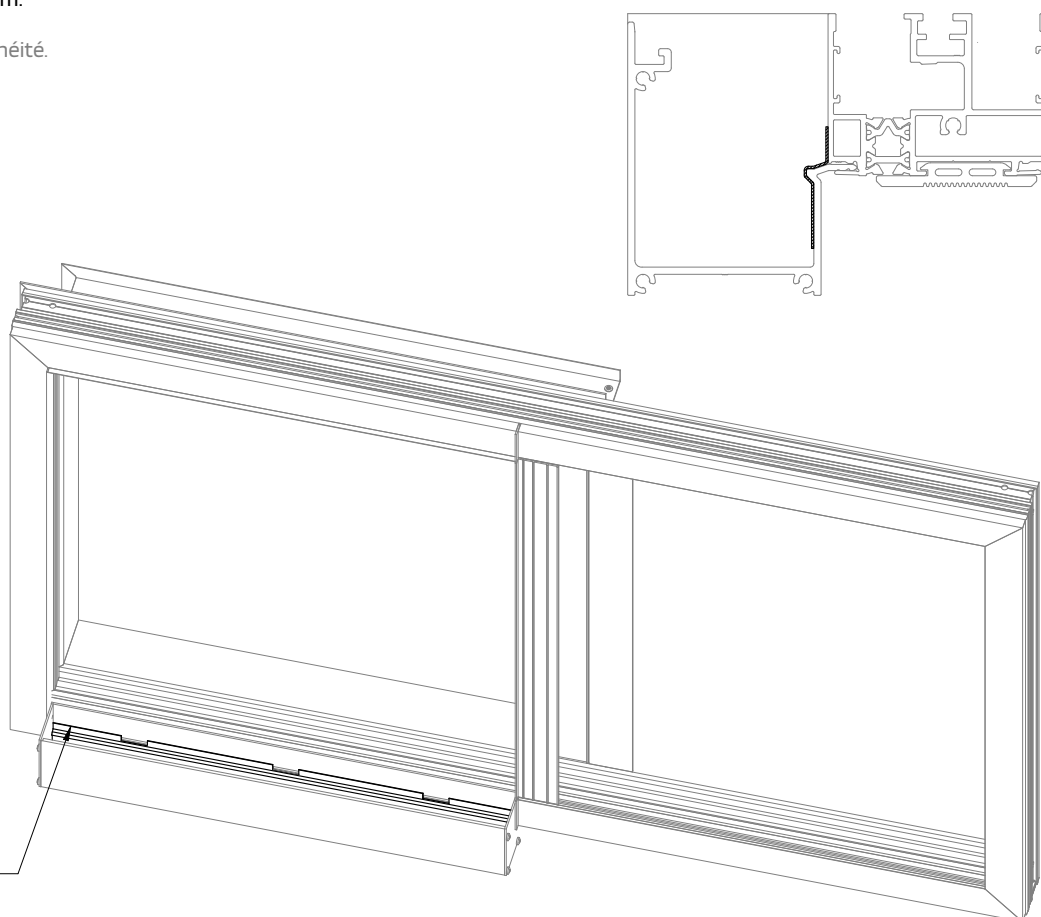



SEQUÊNCIA DE MONTAGEM DO CAIXILHO
FRAME ASSEMBLY SEQUENCE
SÉQUENCE DE MONTAGE DU CHÂSSIS

18 - Isolar bem as duas extremidades da caleira com silicone neutro.

Seal both ends of the gutter well with neutral silicone.

Isoler bien les deux extrémités de la gouttière avec du silicone neutre.

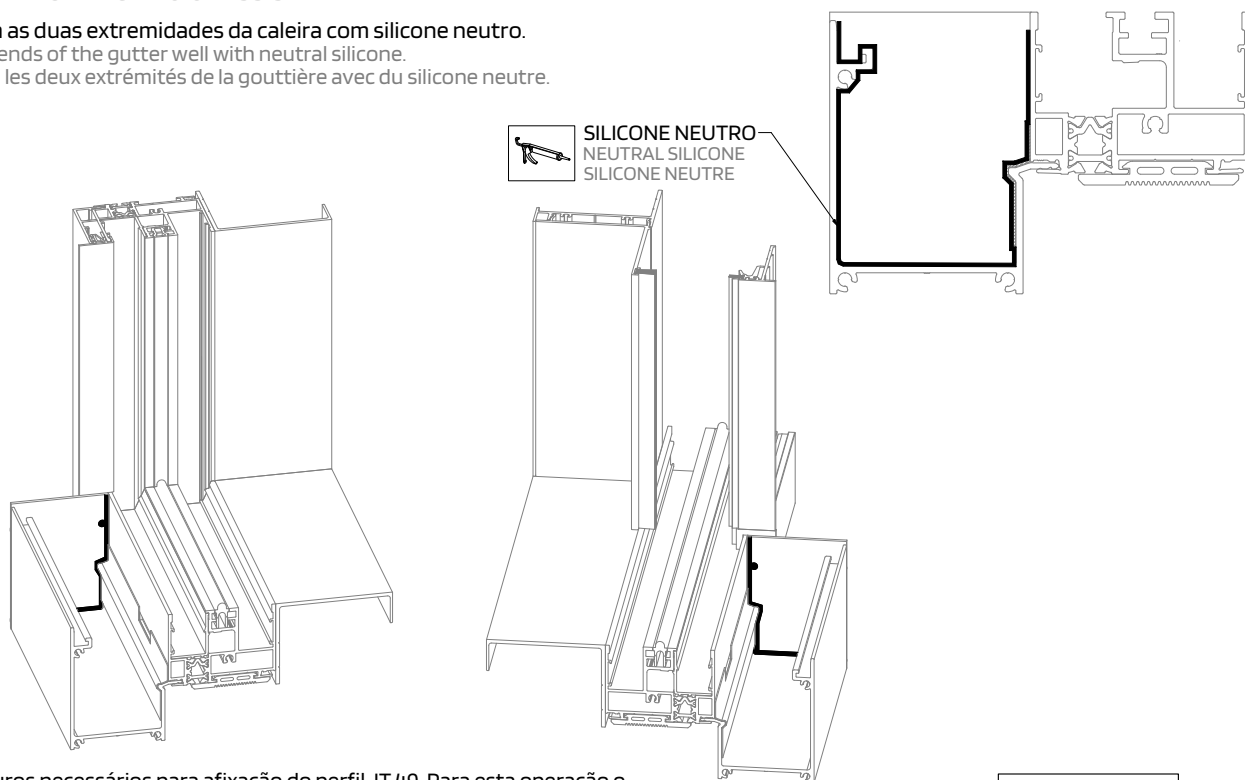

19 - Fazer os furos necessários para afiação do perfil JT 49. Para esta operação o perfil JT 87 não pode estar aplicado.

Drill the necessary holes for fixing the JT 49 profile. For this operation, the JT 87 profile cannot be applied.

Perçer les trous nécessaires à la fixation du profilé JT 49. Pour cette opération, le profilé JT 87 ne peut pas être appliqué.

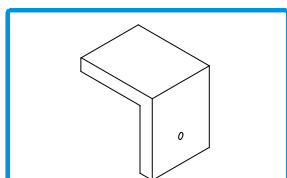

Para furação para paraf. 290472
 Material: Inox | Acabamento: Inox

211209 GABARITO FURAÇÃO CALEIRA JT Nº1

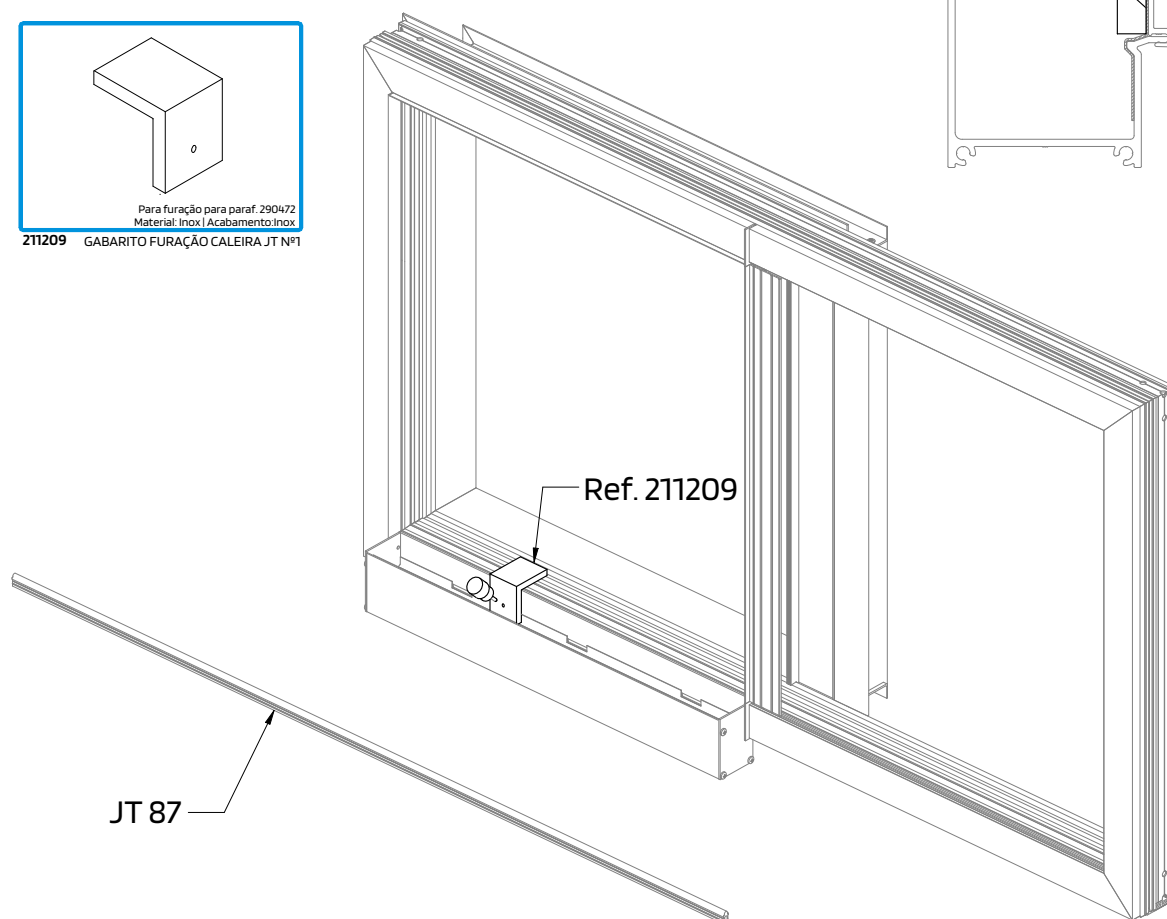



SEQUÊNCIA DE MONTAGEM DO CAIXILHO
FRAME ASSEMBLY SEQUENCE
SÉQUENCE DE MONTAGE DU CHÂSSIS

- 20 - Colocar as goteiras antes de fixar o perfil JT 49.**
 Place the gutters before fixing the JT 49 profile.
 Placer les gouttières avant de fixer le profilé JT 49.

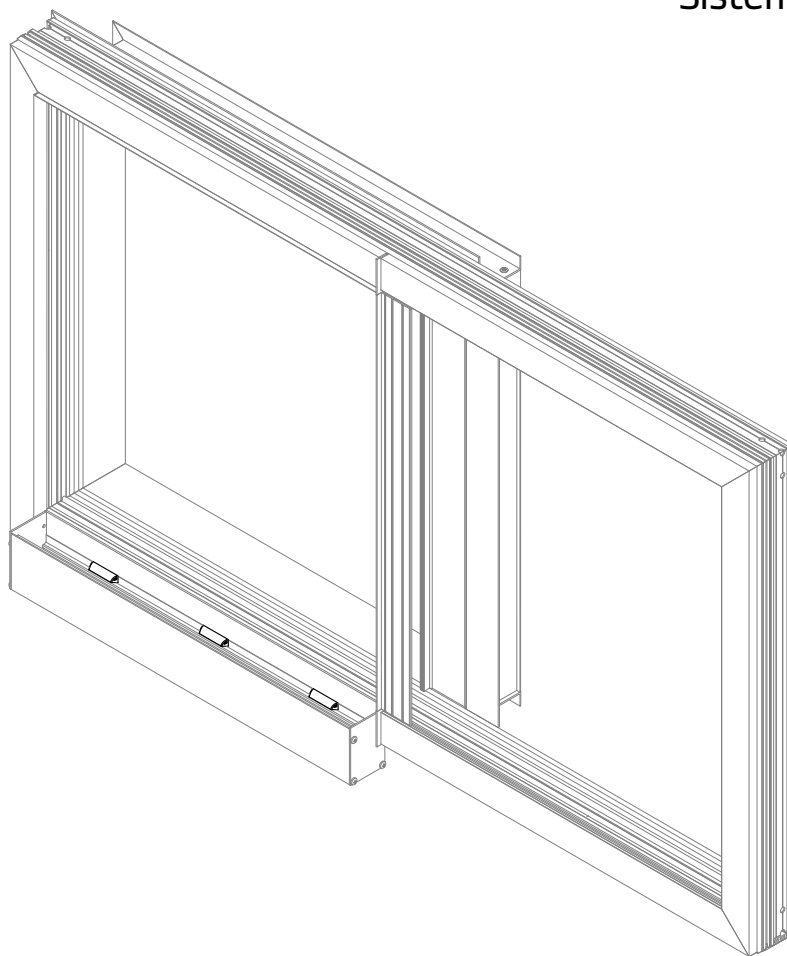
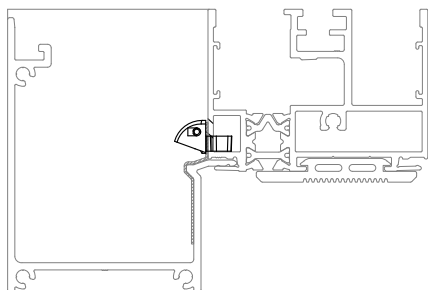
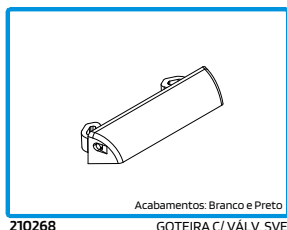

- 21 - Fixar o perfil JT 49 com os parafusos (Ref. 290472).**
 Fix the JT 49 profile with screws (Ref. 290472).
 Fixer le profilé JT 49 à l'aide des vis (Ref. 290472).

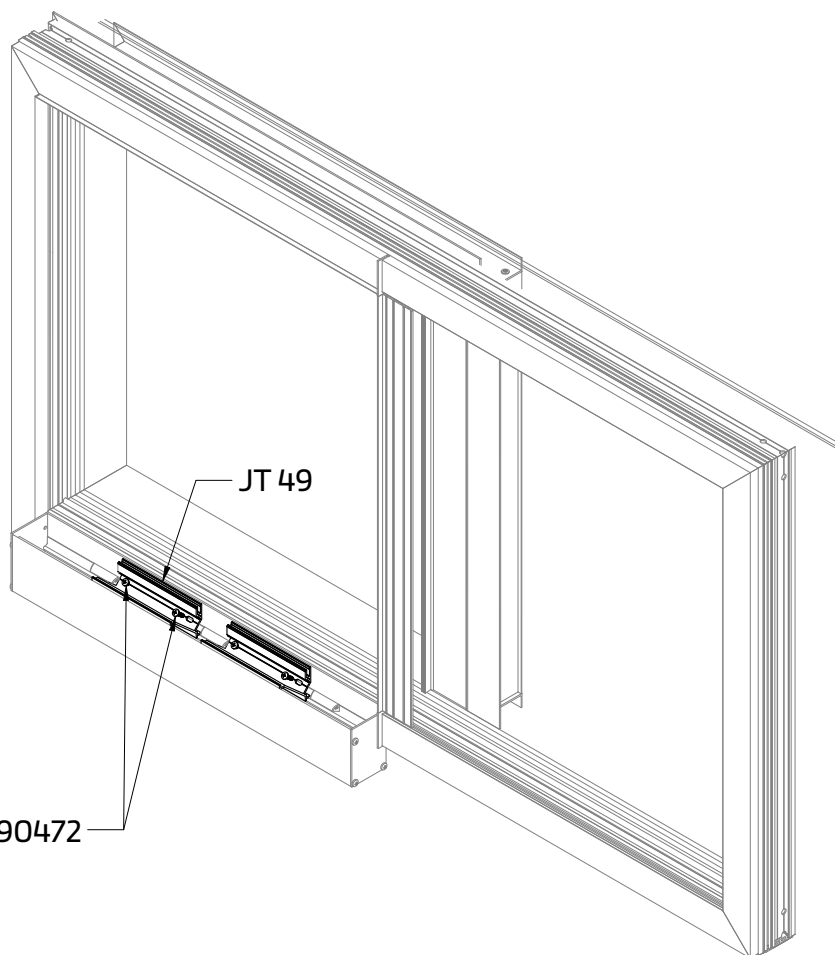
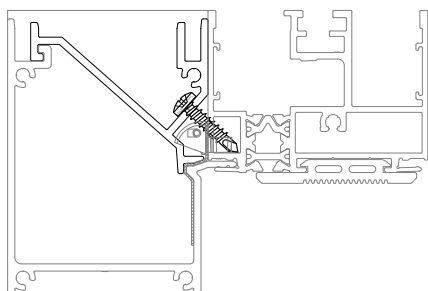
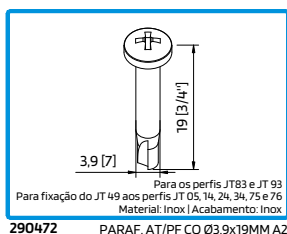



SEQUÊNCIA DE MONTAGEM DO CAIXILHO
FRAME ASSEMBLY SEQUENCE
SÉQUENCE DE MONTAGE DU CHÂSSIS

- 22 - Colocar o perfil SO 58.
Place the SO 58 profile.
Placez le profil SO 58.

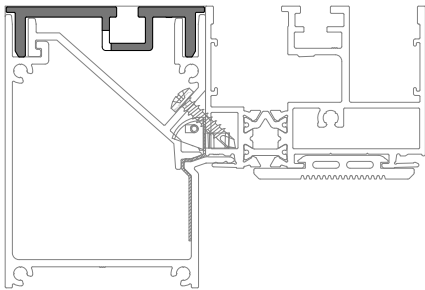
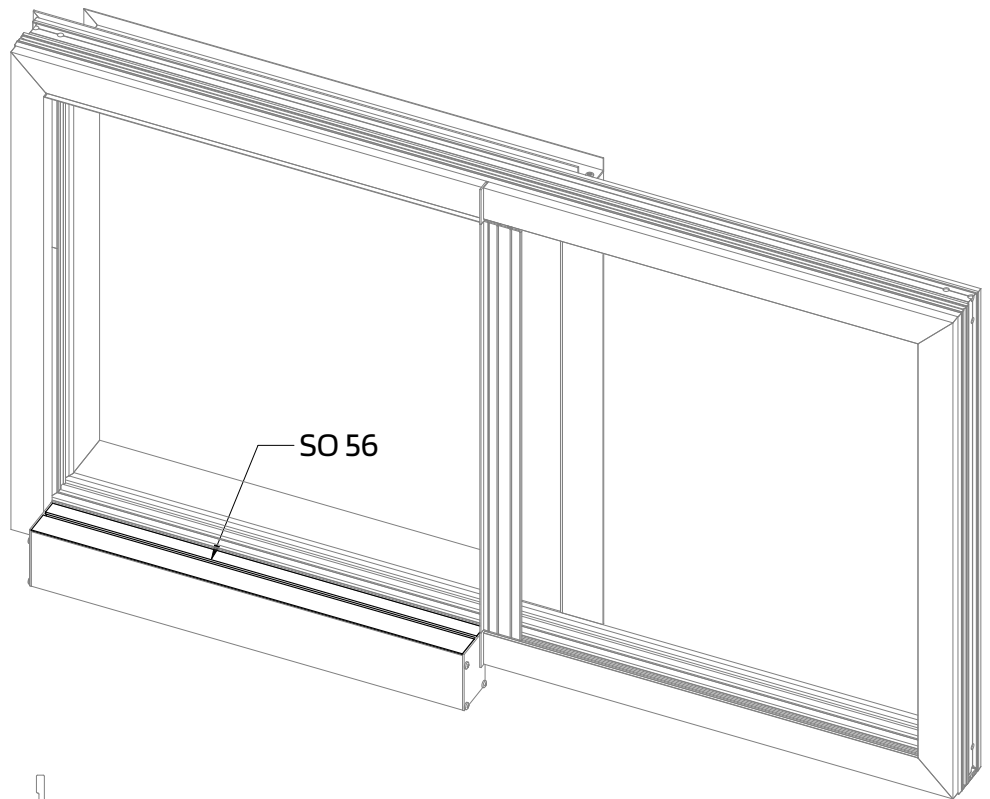



SEQUÊNCIA DE MONTAGEM DO CAIXILHO
 FRAME ASSEMBLY SEQUENCE
 SÉQUENCE DE MONTAGE DU CHÂSSIS

Tipologias com perfis *Renovatio*

Typologies with *Renovatio* profiles | Typologies avec profils *Renovatio*:

22.1 - Aplicar pontos de cola para a colagem dos topos na soleira KE 71.

Apply dots of glue to glue the end-caps onto the KE 71 sill.

Application de points de colle pour coller l'embouts sur le seuil KE 71.

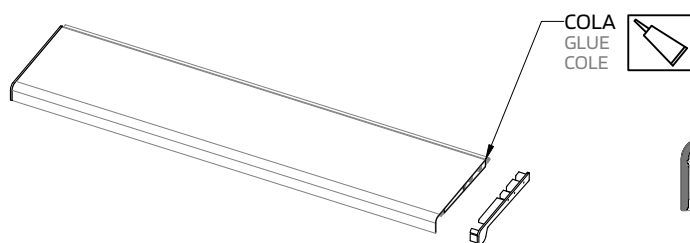
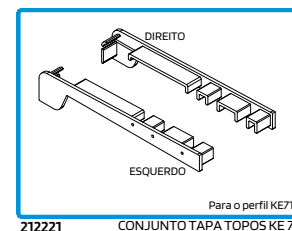

22.2 - Encher a câmara com silicone neutro antes de colocar a soleira.

Fill the chamber with neutral silicone before placing the sill.

Remplir la chambre avec du silicone neutre avant de placer le seuil.

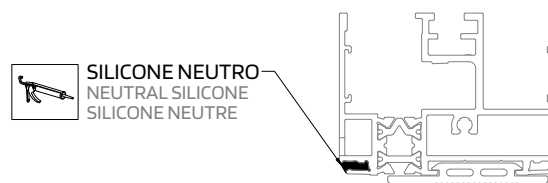

22.3 - Colocar o perfil KE 71 no aro fixo.

Place the KE 71 profile on the fixed frame.

Placer le profilé KE 71 sur le dormant.

